

# TKM COLLEGE OF ENGINEERING

(Government Aided and Autonomous)

celebrating 60 years of excellence



---

## **ELECTRONICS AND COMMUNICATION ENGINEERING**

**B. Tech Curriculum 2024  
&  
First & Second Semester Syllabus**

THANGAL KUNJU MUSALIAR COLLEGE OF ENGINEERING  
(Government Aided and Autonomous)  
KOLLAM-691005, KERALA

Abstract

TKMCE- Academics- B.Tech Electronics & Communication Curriculum 2024 -  
orders issued

No:ACU3/627/2024

Date:03/09 /2024

**Order**

Read:

1. Minutes of the V Academic Council Meeting held on 31/07/2024

The fifth Academic council meeting held on 31st July 2024, approved the B.Tech Electronics and Communication Engineering Curriculum 2024 (B.Tech admissions 2024 onwards till next revision). The academic curriculum for the B.Tech Electronics & Communication Engineering programmes, 2024 approved by the Academic Council, is hereby notified as the **TKM College of Engineering (Aided and Autonomous) B.Tech Electronics & Communication Engineering Curriculum 2024.**

Orders are issued accordingly

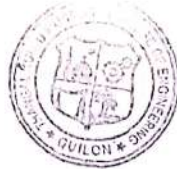

  
PRINCIPAL IN-CHARGE  
THANGAL KUNJU MUSALIAR  
COLLEGE OF ENGINEERING  
KOLLAM - 691 005

Copy to: All HODs, Deans, IQAC, COE, AA, AO, SS, JS(A)

THANGAL KUNJU MUSALIAR COLLEGE OF ENGINEERING  
(Government Aided and Autonomous)  
KOLLAM-691005, KERALA

Abstract

TKMCE- Academics- B.Tech S1& S2 Electronics & Communication Syllabus 2024 -  
orders issued

No:ACU3/634/2024

Date:03/09 /2024

**Order**

Read:

1. Minutes of the V Academic Council Meeting held on 31/07/2024

The fifth Academic council meeting held on 31st July 2024, approved the B.Tech Electronics and Communication Engineering First Year (S1& S2 semester ) syllabus to be followed for the academic year 2024-25 onwards till the next revision .

Orders are issued accordingly



  
PRINCIPAL IN-CHARGE  
THANGAL KUNJU MUSALIAR  
COLLEGE OF ENGINEERING  
KOLLAM - 691 005

Copy to: All HODs, Deans, IQAC, COE, AA, AO, SS, JS(A)

## Preface to the Curriculum

The new undergraduate curriculum of TKM College of Engineering is designed to provide students with the skills and knowledge they need to become competent engineers capable of tackling real-world problems in a variety of fields. The curriculum is carefully designed to expose students to both theoretical and practical aspects of engineering and provide them with hands-on experience in the latest technologies and tools used in the industry. The courses given in the curriculum are tailored in a student centric fashion to ensure that they receive well-rounded education with the flexibility to customize their own learning experience according to their interests and career goals.

The allocation of 170 credits, of which 167 are from courses and 3 from activity points, over a period of four years, with each year comprising of two semesters. All courses in the curriculum are designed to highlight the significance of applying knowledge to engineering and technology challenges, fostering creativity, innovation, and developing entrepreneurial capabilities.

The curriculum includes project-based courses that emphasize hands-on learning and real-world applications supported by the fundamentals of engineering. These courses are offered with lab components, which allow students to gain practical experience in applying the concepts that they have learned. Additionally, there are basic science courses with lab components, core courses without practical components and lab courses to provide breadth wise knowledge in the area of recent technological trends. These variety of courses ensure that students receive a well-rounded education. They also get the flexibility to customize their own learning experience according to their interests and career goals. In addition to the core courses, students have the opportunity to choose from a wide range of elective courses in specialized areas.

The industry internship included in the curriculum will give students the opportunity to apply their theoretical knowledge to practical situations and expand their industrial knowledge. The students can opt for MOOC courses corresponding to Professional Elective and Open Elective Courses during their 7<sup>th</sup> and 8<sup>th</sup> semesters, which will give them opportunity for doing internships.

Moreover, the extracurricular activities that students can participate in to earn activity points will provide them with a well-versed education and help them develop important skills such as leadership, teamwork, and communication. This is a great initiative to ensure that students not only excel academically but also develop important life skills that will help them in their future endeavours.

## GENERAL COURSE STRUCTURE

### 1. Credit and Courses:

Classification	Credit assigned
1 Hour Lecture [L] per week	1 Credit
1 Hour Tutorial [T]per week	1 Credit
1 Hour Project [J] per week	1 Credit
2 Hours Practice/Practical [P] per week	1 Credit

Credits are a unit of measurement for course work and are based on the number of hours of instruction required per week. One hour of classroom lecture (L) that is 60 minutes long per week, is considered as one Instructional Unit or one Credit. The same goes for a tutorial (T) or a project (J) that is 60 minutes long per week.

In addition, a minimum of 2hours per week of laboratory session, practical or field work, training (P) or a combination of these, carried out during all weeks of the semester, is also considered one Instructional Unit or one Credit.

**Credit pattern**

The B.Tech. program curriculum has a total of 167 academic credits and 3 additional pass/fail credits that can be gained through 100 activity points. The program will accommodate courses from other disciplines also, so that students have multi-disciplinary exposure. Additionally, the program provides sufficient opportunities for students to enhance their communication, soft skills and managerial skills, along with technical skills. Depending on the program, the courses fall under engineering, basic science, humanities science, and management categories. The structure of the UG program essentially have the following categories of courses with the breakup of credits as given below:

Sl No:	Category	Code	Credit Breakup
1	Humanities and Social Sciences including Management courses	HSMC	16
2	Basic Science courses	BSC	22
3	Engineering Science courses including workshop, drawing, basics of electrical/mechanical/computer etc.	ESC	27
4	Professional Core Courses	PCC	59
5	Professional Elective courses relevant to chosen specialization/ branch	PEC [MS]	[IEC] 12
6	Open Electives – Electives from other technical and /or emerging areas	OEC	
7	Major Project, seminar and internship in industry or elsewhere	PROJ	17
8	Mandatory Courses	MC	5
9	Mandatory Student Activities	SA	3
Total Credit			<b>170</b>
<b>Optional Specialization</b>			
10	Honors	HR	20
11	Minor	MR	20
Total credits with optional specialization			<b>190</b>

10 to 15 % deviation in credits is permitted under each discipline. While developing the curriculum, the department offering the program should ensure that the above distribution shall be attained by the students upon their completion of their program. Either Minor or Honors can be opted from the optional specialization.

The courses are organized into 1/2/3/4/5/6/14 credit courses based on the content delivery mechanism and desired depth of the course. The delivery methods include Theory-only, Theory with tutorial, Theory with practice, Theory with project etc. The L-T-P-J notation for each course signifies the allocation of hours for content delivery in terms of Lecture (L), Tutorial (T), Practical (P), and Project (J) per week, as well as the credit earned from the course. Apart from lecture, tutorial, practical/practice and the project hours, the curriculum offers Self learning hours(S) that indicates the number of hours students are expected to spent for activities outside the class defined by the faculty handling courses, and for the activities that support learning, initiated by the students themselves without the guidance from the faculty concerned. For each course, Self-learning hours per week is calculated as:

$$S = (L*1+T*0+P*1+[J/2])$$

where J belongs to the project component of a project-based course. Thus, the L-T-P-J-S-C for each course indicates the number of hours scheduled as Lecture (L), Tutorial (T), Practical (P), Project (J), Self-study hours (S) and the total instructional delivery indicated as Credits (C).

$$C = L+ T + [P/2] + J$$

For mandatory courses, irrespective of number of hours allotted in L-T-P-J the credit assigned will be 1.

S1 No.	Lecture-Tutorial-Practical/ Project [L-T-P-J]	Self-learning hours[S]	Credit [C]	Description
1	1-0-0-0	1	1	Theory course without End Semester Examination [ESE]
2	2-0-0-0	2	2	
3	2-0-2-0	4	3	Theory course integrated with practical
4	2-2-0-0	2	4	Theory course with tutorial
5	2-1-0-0	2	3	
6	3-1-0-0	3	4	
7	3-0-0-0	3	3	Theory course
8	3-1-2-0	5	5	Theory course integrated with practical and tutorial
9	2-1-2-0	4	4	
10	1-0-2-0	3	2	Theory course integrated with practical without ESE
11	3-0-2-0	5	4	Theory course integrated with practical
12	2-0-2-2	5	5	Project based course
13	0-0-2-0	2	1	Practical course without ESE
14	0-0-4-0	4	2	Practical course without ESE
15	0-0-6-0	6	3	Seminar
16	0-0-14-0	12	7	Major Project
<b>Mandatory Courses with 1 credit</b>				
17	2-0-0-0	2	1*	Theory Courses
	3-0-0-0	3		
18	2-0-2-0	4	1*	Theory course integrated with lab
19	0-0-0-2	1	1*	Socially Relevant Project
<b>Minor/ Honors Course</b>				
20	4-0-0-0	4	4	Theory course
21	0-0-0-4	2	4	Project only course

\*Credit for Mandatory Courses



### **Course Category:**

In general, the curriculum of each program consists of courses that are categorised into different heads such as Program Core (PCC), Professional Elective (PEC), Project-based courses (PBC), and Open Elective courses (OEC). The details of such courses are given below.

#### Program Core (PCC) or Professional Core

Program or Professional Core (PCC) courses are program-specific and are typically designed to provide students with a strong foundation in the core concepts and skills of their chosen field of study. By completing the PCC courses, students will have a solid understanding of the fundamental principles and practices in their field, which will prepare them for more advanced coursework and professional work in the future.

#### Project Based Course (PBC):

Project-based courses (PBC) are designed to provide students with a deeper knowledge and understanding of real-world challenges and problems in their field of study. Through PBC courses, students have the opportunity to actively explore and apply theoretical knowledge to real-world problems. This can help them develop problem-solving skills and gain practical experience that will be valuable in their future careers. Doing multiple projects can also help students develop a range of skills that include project management, teamwork, communication and presentation skills.

#### Professional Elective (PEC):

Professional Elective (PEC) courses are designed to provide students with an opportunity to study more advanced, applied, or specialized courses than the basic courses they study as part of their program or professional core courses. PEC courses can help students gain in-depth knowledge of a specific sub-field. These courses are typically more focused and specialized than program core courses, and can help students develop expertise in a particular area in their discipline.

PEC courses provide students with the flexibility to tailor their education to their interests and career goals.

#### Micro specialization:

Electives can be streamlined to certain sub-disciplines of the B.Tech program, which are sometimes referred to as micro-specializations. This allows students to graduate with different micro-specializations by selecting a set of professional elective courses that are aligned with industry requirements or higher studies. A micro-specialization can be acquired by opting any two theory courses from the list of professional electives which is in line with a Program Core Course.

#### Open Elective courses (OEC):

Open Electives are courses that students need to study in other discipline alongside their primary area of study. These courses are designed to give students greater flexibility over their curriculum, allowing them to pursue their interests and passions. Open Electives promote cross-disciplinary and multidisciplinary learning. Students have the freedom to choose suitable courses from different streams. This can be a great way to broaden the knowledge and skills and to explore new areas of interest.

#### Seminar

Seminars are given to provide opportunity for students to make technical presentation on their research or ideas on a specific topic, to a peer audience. Seminars can be used to enhance students' communication skills, critical thinking skills, and ability to synthesize information from technical publications. It can be also used to encourage

students to read and collect recent and reliable information from technical publications including peer-reviewed journals, conference papers, books, project reports, and other sources. The purpose of seminars is to create a learning environment where students can engage in active discussions and develop their presentation skills. Participating in seminars, students can gain valuable experience and develop the skills they need to succeed in their future careers.

#### Major Project:

Every student need to complete major project that spans through 7<sup>th</sup> and 8<sup>th</sup> semester. The project in the seventh semester shall be continued as the project in the eighth semester.

Minor and Honours courses: The Minor in Engineering program allows students to obtain degree in another domain. They also get interdisciplinary experience and exposure to concepts and perspectives.

- The student should earn additional 20 credits to be eligible for the award of B. Tech Degree with Minor.
- Out of the 20 credits, 12 credits should be earned by undergoing a minimum of three courses, of which one course shall be a mini project based on the chosen area.
- The remaining 8 credits could also be acquired through 2 MOOCs.

This program gives a great opportunity for students to broaden their understanding of the engineering profession.

#### Honors

Honors is intended for a student to gain advanced knowledge in an area with their B.Tech discipline in emerging/advanced areas in the branch of engineering concerned. Upon completion of Honors, a student will be better equipped to perform research in their branch of engineering.

- The student should earn additional 20 credits to be eligible for the award of B. Tech Degree with Honors.
- Out of the 20 credits, 12 credits should be earned by undergoing a minimum of three courses, of which one course should be a mini project based on the chosen specific area.
- The remaining 8 credits could be acquired through 2 MOOCs

#### Activity points:

To qualify for a B. Tech degree, all students are required to earn 100 activity points from various activity segments listed by the institution. These activity points are awarded on a pass/fail basis and are mandatory for obtaining the degree. While these activity points carry three credits, no grade is given for these credits, and they are not included in the calculation of the CGPA. The purpose of these activity points is to encourage students to participate in various extracurricular activities, such as sports, cultural events, and community service. For lateral entry students who join from the third semester, the activity point requirement is reduced to 75. The points earned by the student will be indicated in the consolidated academic statement, which is a record of the student's academic performance during their program.

The activity points can be earned by undertaking activities from different categories. Some of the categories are:

- (i) Internship



- (ii) MOOC/GRE/ TOEFL /GATE/ IELTS/MAT/SAT/CAT etc/ Foreign language proficiency
- (iii) Participation and organization of Co-curricular activities, Extracurricular activities.

Detailed list of activities and the related points are published along with the curriculum.

### **Socially Relevant Projects**

The main purpose of Socially Relevant Projects is to connect the students with the society for mutual benefit. The community will benefit from the focused contribution of students towards local development. At the same time, the institution finds an opportunity to develop social sensibility and responsibility among students.

The objectives of Socially Relevant Projects are:

- ✓ To provide students with an opportunity to engage in meaningful community service and apply their learning to real-world situations.
- ✓ To promote civic responsibility and leadership skills among students, and to foster a deeper understanding of social issues.
- ✓ To facilitate the development of partnerships between colleges and local communities, and to contribute to local development.
- ✓ To encourage students to think critically and creatively about social issues, and to develop innovative solutions to address them.
- ✓ To promote interdisciplinary learning and collaboration, and to provide opportunities for students to apply their knowledge and skills across different fields.

### **Activities for Socially Relevant Project**

- ❖ Conducting surveys and research on social issues and concerns to gain a better understanding of the problem and identify potential solutions.
- ❖ Developing and implementing educational programs to promote awareness and understanding of social issues and concerns.
- ❖ Collaborating with local NGOs and community groups to organize events and activities that promote social welfare and community development.
- ❖ Developing and implementing social welfare programs that address the needs of marginalized and vulnerable communities, such as homeless individuals, refugees, and low-income families.
- ❖ Conducting community service activities, such as volunteering at local shelters, food banks, and community centers.
- ❖ Developing and implementing environmental conservation programs that promote sustainable practices and reduce the impact of human activities on the environment.
- ❖ Creating and distributing educational materials, such as pamphlets and brochures, to raise awareness about social issues and concerns.
- ❖ Organizing fundraising events to support social welfare programs and community development initiatives.
- ❖ Engaging in advocacy and lobbying efforts to influence public policy and promote social justice.

### Procedure for doing Socially Relevant Project

- ❖ Assign a group of students or a single student to a particular habitation, village, or municipal ward in the near vicinity of their place of stay.
- ❖ Conduct a survey of the habitation to gain a better understanding of the social issues and concerns that need to be addressed. A common survey format could be designed to ensure consistency.
- ❖ Develop a project work related to the student's domain or subject area that addresses the identified social issues and concerns. The project should be designed to be socially relevant and have a positive impact on the community.
- ❖ Implement the project work with the help of the local community and relevant authorities. This could include organizing awareness programs, developing and implementing educational programs, conducting community service activities, and engaging in advocacy and lobbying efforts.
- ❖ Monitor and evaluate the project work to ensure that it is having the desired impact on the community. This could include conducting surveys and research, gathering feedback from the local community, and tracking key performance indicators.
- ❖ Document the project work and its impact on the community, and share the findings with relevant stakeholders, including the local community, government authorities, and academic institutions

### Internships

Internships offer students an excellent opportunity to gain industry exposure and prepare for their future work environment. All B.Tech students shall complete a minimum of six to eight weeks of internship in any reputed industry, research organization, or another esteemed institute of higher learning. This requirement can be fulfilled any time after their first year of study and before the seventh semester. The training can be undertaken in a single stretch or in segments, with each segment lasting at least two weeks. Students should select the organization for their internship in consultation with their senior faculty advisor. Additionally, the curriculum provides the option to undertake full-semester internship in the 7th or 8th semester.

### **Structure of Course code:**

Each course will be identified by a unique Course Code consisting of eight alphanumeric characters (Two digits, three alphabets which together followed by three digits) and is represented as **YYXXCSNN**, which can be interpreted as: YY – Regulation Year XX - Stream Code C- Course Delivery Mode, S – Semester Number (it can have a number from 1 to 8) NN- Course Sequence Number

For eg: 24CET303- is a theory course offered by the civil engineering department in the third semester of the 2024 scheme.

24MEL408 - is a laboratory course offered by the mechanical engineering department in the fourth semester of the 2024 scheme.

24CSP607 - - is a laboratory course offered by the computer science department in the sixth semester of 2024 scheme.

<b>Year of Regulation YY</b>	<b>Course category XX</b>	<b>Course delivery mode C</b>	<b>Semester Number S</b>	<b>Serial No. of course NN</b>
24 for 2024 regulation	BY -BIOLOGY	T - THEORY ALONE	1	01
	CE - CIVIL ENGINEERING	P - THEORY INTEGRATED WITH PRACTICAL COURSE	2 3 etc.	02 03 etc.
	CH - CHEMICAL ENGINEERING	L-LABORATORY COURSE		
	CS - COMPUTER SCIENCE &ENGINEERING	J - THEORY NTEGERATED WITH PROJECT (PROJECT BASED COURSE)		
	CY – CHEMISTRY	E – PROFESSIONAL ELECTIVE COURSE		
	EC- ELECTRONICS & COMMUNICATION ENGINEERING	O - OPEN ELECTIVE COURSE		
	EE – ELECTRICAL & ELECTRONICS ENGINEERING	H - HONORS COURSE		
	ER – ELECTRICAL & COMPUTER ENGINEERING	M - MINOR COURSE		
	AI – COMPUTER SCIENCE & ENGINEERING[AI]	S - SEMINAR		
	ES - ENGINEERING SCIENCE COURSE	R - RESEARCH BASED MINI PROJECT		
	HU - HUMANITY, SOCIAL SCIENCE AND MANAGEMENT	D - PROJECT		
	MA - MATHEMATICS	N - INTERNSHIP		
	MC- MANDATORY COURSE			
	ME - MECHANICAL ENGINEERING			
PY – PHYSICS				

### Assessment

In each semester, students shall be evaluated both by Continuous Internal Assessment (CIA) and End Semester Examinations (ESE) or by Continuous Internal Assessment alone based on the credit assigned to the course. The Continuous Internal assessment shall be on the basis of the day-to-day work, periodic tests, assignments, quizzes, presentations and other suitable tools devised by the faculty. The faculty member(s) concerned should carry out the CIA for the courses allotted to them in the following perspectives with respect to all courses:

- Evaluation with respect to knowledge
- Evaluation with respect to Understanding
- Evaluation with respect to skill
- Evaluation with respect to Applications and/or
- Higher Order Thinking Skills

For the Practice part of a course or a pure Practice (Laboratory/Practical) course; due weightage shall be given for carrying out experiments, observations, collection of data, analysis, interpretation of results, inference etc. Timely submission of record work shall also carry due weightage based on the type of laboratories and the course. The CIA marks for individual courses shall be computed by giving weightage to the parameters given in the table below.

Mark Distribution of CIA										
Course Structure [L-T-P-J]	Attendance	Theory [L- T]				Practical [P]		Project [J]		Total Marks
		Assignment	Test-1	Test-2	#Classes work	Lab Exam	Evaluation 1	Evaluation-2	Report	
1-0-0-0	5	25	20	-	-	-	-	-	-	50
2-0-0-0	5	35	30	30	-	-	-	-	-	100
1-0-2-0	5	10	20	-	25	40	-	-	-	100
0-0-2-0	5	-	-	-	35	10	-	-	-	50
0-0-4-0	5	-	-	-	25	30	-	-	-	60
2-1-0-0	5	15	10	10	-	-	-	-	-	40
3-0-0-0	5	15	10	10	-	-	-	-	-	40
3-1-0-0	5	15	10	10	-	-	-	-	-	40
4-0-0-0	5	15	10	10	-	-	-	-	-	40
2-0-2-0	5	10	-	15	15	15	-	-	-	60
3-1-2-0	5	10	12.5	12.5	10	10				60
2-1-2-0	5	10	12.5	12.5	10	10	-	-	-	60
3-0-2-0	5	10	12.5	12.5	10	10	-	-	-	60
2-0-2-2	5	10	-	15	10		5	10	5	60

<b>2-2-0-0</b>	5	10	12.5	12.5					<b>40</b>
<b>^2-0-2-0</b>	5	10	20		*45	20			<b>100</b>
<b>&amp;0-0-4-0</b>	5				55	40			<b>100</b>

^ For Idea lab only, & For Manufacturing Practices only \*Split up is given in the syllabus

### Assessment of Assignment component of CIA

Based on the course category the number of assignments that shall be given for each course may vary. The table given below gives the details about it.

Course Category	L-T-P-J	Credit	Assessment of Assignment component of CIA
Theory Course	1-0-0-0	1	One assessment per two and half module
	2-0-0-0	2	
Theory Embedded with Practical	1-0-2-0	2	
Theory Course	2-1-0-0	3	Minimum two assessments per two and half modules. If more numbers are given, best two shall be considered for the calculation of CIA.
	2-2-0-0	4	
	3-0-0-0	3	
	3-1-0-0	4	
	4-0-0-0	4	
Theory Embedded with Practical	2-0-2-0	3	
	3-1-2-0	5	
	2-1-2-0	4	
	3-0-2-0	4	
Project Based Course	2-0-2-2	5	

### Evaluation Type, CIA & ESE Mark Distribution:

The evaluation type, CIA & ESE mark distribution for courses with various course structures are given in the following table:

Evaluation Type	Course Category	L-T-P-J	Credit	CIA Mark	ESE Mark	CIA %	ESE %
CIA only	Theory Course	1-0-0-0	1	50	-	100%	-
		2-0-0-0	2	100			
	Theory integrated with Practical	1-0-2-0	2	100			
	Practical	0-0-2-0	1	50			
		0-0-4-0	2	100			
	Seminar	0-0-6-0	3	100			
	Project [Minor/Honor]	0-0-0-4	4	100			
Major Project	0-0-14-0	7	100				
CIA + ESE	Theory Course	2-1-0-0	3	40	60	40%	60%
		2-2-0-0	4				
		3-0-0-0	3				

		3-1-0-0	4	60	40	60%	40%
		4-0-0-0	4				
	Theory integrated with Practical	2-0-2-0	3				
		3-1-2-0	5				
		2-1-2-0	4				
		3-0-2-0	4				
	Project Based Course	2-0-2-2	5				

### Evaluation pattern for End Semester Examination

The end-semester examination shall have the learning assessments from the following perspectives for all courses:

- Evaluation with respect to Knowledge
- Evaluation with respect to Understanding
- Evaluation with respect to Applications

Separate evaluation pattern shall be followed for ESE, as given in table below.

PATTERN	PART A	PART B	ESE Marks
PATTERN 1	10 Questions, each question carries 2 marks Marks: (2x10 =20 marks)	2 questions will be given from each module, out of which 1 question should be answered. Each question can have a maximum of 2 sub divisions. Each question carries 8 marks. Marks: (5x8 = 40 marks) Time: 3 hours	<b>60</b>
	Total Marks: 20	Total Marks: [5x8 = 40 marks]	
PATTERN 2	NIL	2 questions will be given from each module, out of which 1 question should be answered. Each question can have a maximum of 2 sub divisions. Each question carries 8 marks. Marks: (5x 8 = 40 marks) Time: 2.5 hours	<b>40</b>
	Total Marks: 0	Total Marks: [5x8 = 40 marks]	
PATTERN 3 [For the course 24EST108/24EST206 Engineering Graphics 2-2-0-0	NIL	2 questions will be given from each module, out of which 1 question should be answered. Each question carries 12 marks. Marks: (5x 12 = 60 marks) Time: 3 hours	<b>60</b>
	Total Marks: 0	Total Marks: [5x12 = 60 marks]	
PATTERN 4 (For the course 24CHP701 Computer-Aided Process Design	NIL	2 Questions, each question carries 40 marks. Each question can have a maximum of 2 sub-divisions. Marks: (1x40 = 40 marks) Time: 2.5 hours	<b>40</b>



(2-1-2-0)	Total Marks: 0	Total Marks: (1x40 = 40 marks)
-----------	----------------	--------------------------------

The condition for passing a course shall be 40% for the End Semester Examination, 40% of CIA, and 50% for CIA and ESE put together. Letter grade 'F' will be awarded to the student for a course if either their marks for the ESE is below 40 % or mark for the CIA is below 40 % or the overall mark [Continuous Internal Evaluation + End Semester Examination] is below 50 %. For courses with only CIA [having no ESE], a minimum of 50% of CIA mark is required for passing.

### Grade and Grade point

Grading is based on the overall percentage marks obtained by the student in a course. The grade card shows the grades obtained for the courses the student has registered. Semester grade card gives the grade for each registered course, Semester Grade Point Average (SGPA) for the semester as well as Cumulative Grade Point Average (CGPA). The details of assigning Grades and the corresponding Grade point are given in the table below.

Grades	Grade Point [GP]	% of Total Marks obtained
S	10	90% and above
A+	9.0	85% and above but less than 90%
A	8.5	80% and above but less than 85%
B+	8	75% and above but less than 80%
B	7.5	70% and above but less than 75%
C+	7.0	65% and above but less than 70%
C	6.5	60% and above but less than 65%
D	6	55% and above but less than 60%
P [Pass]	5.5	50% and above but less than 55%
F [Fail]	0	Below 50% (CIA + ESE) or Below 40 % for ESE Below 40 % for CIA Below 50% for courses with only CIA and no ESE
FE	0	Failed due to lack of eligibility criteria
I	0	Could not appear for the end semester examination but fulfils the eligibility criteria.
First Class with Distinction		CGPA 8.0 and above
First Class		CGPA 6.5 and above
Equivalent percentage mark shall be = 10 * CGPA		

**Allotted and Cumulative Credits**

The allotted and cumulative credits of circuit and non- circuit branches are given in table below

Semester	Circuit branches [CS, EC, EE &ER]		Non-Circuit branches [CE, ME &CH]	
	Allotted Credits	Cumulative Credits	Allotted Credits	Cumulative Credits
First	20	-	23	-
Second	23	43	21	44
Third	24	67	23	67
Fourth	22	89	22	89
Fifth	21	110	21	110
Sixth	20	130	20	130
Seventh	21	151	21	151
Eighth	16	167	16	167

**Circuit branches:** Computer Science & Engineering [CS], Electronics & Communication [EC], Electrical &Electronics [EC] and Electrical &Computer Science [ER]

**Non-Circuit branches:** Civil [CE], Mechanical [ME] and Chemical Engineering [CH]

**CURRICULUM 2024**  
**ELECTRONICS & COMMUNICATION ENGINEERING**

FIRST SEMESTER													
SI No	Slot	Code	Category	Title	L	T	P	J	S	No. of Hours	No. of Credits	Total Marks	
												CIA	ESE
1	A	24MAT101	BSC	Calculus and Linear Algebra	3	1	0	0	3	4	4	40	60
2	B	24PYP102	BSC	Engineering Physics	2	1	2	0	4	5	4	60	40
3	C	24EST104	ESC	Fundamentals of Electrical Engineering	3	0	0	0	3	3	3	40	60
4	D	24ESP107	ESC	Technical English for Engineers	2	0	2	0	4	4	3	60	40
5	N	24MCJ110	MC	IDEA Lab Workshop	2	0	2	0	4	4	1*	100	
6	O	24HUL111	HSMC	Design Thinking	0	0	2	0	2	2	1	50	
7	J	24BST120	BSC	Biology for Engineers	2	0	0	0	2	2	2	100	
8	I	24ESP121	ESC	Electronic Design and Simulation	1	0	2	0	3	3	2	100	
<b>TOTAL</b>									<b>25</b>	<b>27</b>	<b>20</b>		

SECOND SEMESTER													
SI No	CIA	ESE	Category	Title	L	T	P	J	S	No. of Hours	No. of Credits	Total Marks	
												CIA	ESE
1	A	24MAP200	BSC	Ordinary Differential Equations and Transforms	3	1	2	0	5	6	5	60	40
2	B	24CYP203	BSC	Engineering Chemistry	2	1	2	0	4	5	4	60	40
3	C	24ESP204	ESC	Problem solving and Programming	3	0	2	0	5	5	4	60	40
4	D	24ESP208	ESC	Engineering Graphics	2	2	0	0	4	4	4	40	60
5	G	24ESL209	ESC	Manufacturing Practices	0	0	4	0	4	4	2	100	
6	K	24MCT210	MC	Sports and Wellness	2	0	0	0	2	2	1*	100	
7	F	24HUT212	HSMC	Universal Human Values-II	2	1	0	0	3	3	3	40	60
<b>TOTAL</b>									<b>27</b>	<b>29</b>	<b>23</b>		

THIRD SEMESTER														
S I N O	Slot	Code	Category	Title	L	T	P	J	S	Hours	Credits	Total Marks		
												CIA	ESE	
1	A	24MAP301	BSC	Advanced Linear Algebra, Complex Analysis and Partial Differential Equations	3	1	2	0	5	6	5	60	40	
2	K	24EST342	ESC	Object Oriented Programming and Data structures	1	0	2	0	3	3	2	100		
3	B	24ECJ303	PBC	Logic Circuit Design	2	0	2	2	5	6	5	60	40	
4	C	24ECT304	PCC	Semiconductor Devices	2	1	0	0	2	3	3	40	60	
5	D	24ECT305	PCC	Network Theory	2	1	0	0	2	3	3	40	60	
6	E	24HUT310	HSMC	Life Skills and Professional Ethics	3	0	0	0	3	3	3	40	60	
7	I	24ECT307	PCC	Computer Architecture	2	0	0	0	2	2	2	100		
8	M / R	24ECM309/ 24ECM310/ 24ECM311	MR/ RL	MINOR/ REMEDIAL	4	0	0	0			4/ 0	40	60	
<b>TOTAL</b>										<b>22</b>	<b>26</b>	<b>23</b>		

FOURTH SEMESTER														
S I N O	Slot	Code	Category	Title	L	T	P	J	S	Hours	Credits	Total Marks		
												CIA	ESE	
1	A	24ECT401	PCC	Probability and Random Processes	2	1	0	0	2	3	3	40	60	
2	B	24ECT402	PCC	Signals and Systems	2	1	0	0	2	3	3	40	60	
3	C	24ECP403	PCC	Analog Circuits	2	1	2	0	4	5	4	60	40	
4	D	24ECJ404	PBC	Microprocessors and Microcontrollers	2	0	2	2	5	6	5	60	40	
5	E	24HUT445	HSMC	Industrial Economics and Management	3	0	0	0	3	3	3	40	60	
6	F	24MCT406	MC	Environmental Sciences	3	0	0	0	3	3	1*	40	60	
7	I	24ECP407	BSC	Machine Intelligence: Methods and Applications	1	0	2	0	3	3	2	100		
8	M/ H/ R	24ECM409/ 24ECM410/ 24ECM411/ 24ECH409/ 24ECH 410	MR/H R/RL	MINOR/HONORS REMEDIAL	4	0	0	0			4/ 4/ 0	40	60	
<b>TOTAL</b>										<b>22</b>	<b>26</b>	<b>21</b>		

FIFTH SEMESTER													
S I N O	Slot	Code	Category	Title	L	T	P	J	S	Hours	Credits	Total Marks	
												CIA	ESE
1	A	24ECT501	PCC	Control Systems	2	1	0	0	2	3	3	40	60
2	B	24ECJ502	PBC	Digital Signal Processing	2	0	2	2	5	6	5	60	40
3	C	24ECT503	PCC	Embedded Systems and IoT	2	1	0	0	2	3	3	40	60
4	D	24ECP504	PCC	Digital Communication	2	1	2	0	4	5	4	60	40
5	E	24HUT545	HSMC	Entrepreneurship and Startups	3	0	0	0	3	3	3	40	60
6	F	24MCT506	MC	Constitution of India	MOOC				3		1*		
7	I	24ECT507	PCC	Linear Integrated Circuits	2	0	0	0	2	2	2	100	
8	M/ H/ R	24ECM509/ 24ECM510/ 24ECM511/ 24ECH509/ 24ECH510	MR/H R/RL	MINOR/HONORS/ REMEDIAL	4	0	0	0			4/ 4/ 0	40	60
<b>TOTAL</b>									<b>21</b>	<b>22</b>	<b>21</b>		

SIXTH SEMESTER													
S I N O	Slot	Code	Category	Title	L	T	P	J	S	Hours	Credits	Total Marks	
												CIA	ESE
1	A	24ECT601	PCC	Applied Electromagnetic Theory	2	1	0	0	2	3	3	40	60
2	B	24ECP602	PCC	VLSI Design	2	1	2	0	4	5	4	60	40
3	C	24ECP603	PCC	Instrumentation and Industrial Automation	2	1	2	0	4	5	4	60	40
4	D	24ECE6X4	PEC	Professional Elective-1	3	0	0	0	3	3	3	40	60
5	E	24ECE6X5/ 24ECI6X5	PEC/IEC	Professional Elective-2/Industry Elective	3	0	0	0	3	3	3	40	60
6	I	24ECP608	BSC	Data Science and Analytics	1	0	2	0	3	3	2	100	
7	U	24SPJ607	MC	Socially Relevant Project	0	0	0	2	1	2	1*	100	
8	F	24ECS606	SR	Seminar	0	0	4	0	4	4	2	100	
9	M / H / R	24ECM609/ 24ECM610/ 24ECM611/ 24ECH609/ 24ECH610	MR/HR/ RL	MINOR/HONORS/REM EDIAL	4	0	0	0			4/4 /0	40	60
<b>TOTAL</b>									<b>24</b>	<b>28</b>	<b>22</b>		



SEVENTH SEMESTER														
Sl No	Slot	Code	Category	Title	L	T	P	J	S	Hours	Credits	Total Marks		
												CIA	ESE	
1	A	24ECP701	PCC	Microwave and Antennas (Internship Students: Online Classes with Virtual Lab)	2	1	2	0	4	5	4	60	40	
2	B	24ECP702	PCC	Computer Networks and Security (Internship Students: Online Classes with Virtual Lab)	2	1	2	0	4	5	4	60	40	
3	C	24ECE7X3	PEC	Professional Elective-3 (Internship Students: MOOC approved by Institute/Online Classes)	3	0	0	0	3	3	3	40	60	
4	D	24ECO7X4/ 24ECI7X4	OEC /IEC	Open Elective 1/ Industry Elective (Internship Students: MOOC approved by Institute/Online Classes)	3	0	0	0	3	3	3	40	60	
5	U	24ECR705	PR	Option1: Major Project Phase 1/Option 2: Internship (4-6 Months)	0	0	14	0	14	14	7	100		
6	M	24ECM709/ 24ECM710/ 24ECM711	PRM	PROJECT IN MINOR	0	0	0	4	0	4	4	100		
7	H /R	24ECH709	HR /RL	HONORS/REMEDIAL	4	0	0	0	0	4	4/0	40	60	
<b>TOTAL</b>										<b>28</b>	<b>30</b>	<b>21</b>		

Students have the option to undertake an internship in either VII<sup>th</sup> or VII<sup>th</sup> Semester

Option1: Work on project within the institute/department under the mentorship of faculty members.

Option 2: Complete a full Semester Internship in an industry/organization

EIGHTH SEMESTER														
S I N O	Slot	Code	Category	Title	L	T	P	J	S	Hours	Credits	Total Marks		
												CI A	ESE	
1	A	24ECE8X1	PEC	Professional Elective-4 /MOOC (Internship Students: MOOC Approved by the Institute/Online Classes)	3	0	0	0	3	3	3	40	60	
2	B	24EC08X2	OEC	Open Elective-2 /MOOC (Internship Students: MOOC Approved by the Institute/Online Classes)	3	0	0	0	3	3	3	40	60	
3	C	24EC08X3	OEC	Open Elective-3/MOOC (Internship Students: MOOC Approved by the Institute/Online Classes)	3	0	0	0	3	3	3	40	60	
4	U	24ECD804/ 24ECN804	PR /IP	PROJECT/INTERNSHIP Option 1: Major Project Phase -II (For the students who have not opted for internship in S8)  Option 2: Internship (4-6 Months)	0	0	14	0	14	14	7	100		
5	H/ R	24ECH809	PRH /RL	PROJECT IN HONORS /REMEDIAL	0	0	0	4			4/ 0	100		
<b>TOTAL</b>									<b>23</b>	<b>23</b>	<b>16</b>			

**Professional Electives and Micro Specialization**

Micro Specialization Group ID	Specialization	Prerequisite Core course (s)
Ms-I	VLSI AND EMBEDDED SYSTEMS	Analog Circuits (S4), Embedded System & IoT(S5)
Ms-II	WIRELESS COMMUNICATION	Digital Communication (S5)
Ms-III	SIGNAL PROCESSING	Digital Signal Processing (S5)

**LIST OF PROFESSIONAL ELECTIVES**

SEMESTER VI		PROFESSIONAL ELECTIVE I		
Sl No	Slot	Code	Category	Title
1	D	24ECE614	PEC	Mixed Signal VLSI Design (Ms-I)
2	D	24ECE624	PEC	Information Theory and Coding (Ms-II)
3	D	24ECE634	PEC	Digital Image Processing and Computer Vision(Ms-III)
4	D	24ECE644	PEC	MEMS
5	D	24ECE654	PEC	Real Time Embedded Systems

SEMESTER VI		PROFESSIONAL ELECTIVE II		
Sl No	Slot	Code	Category	Title
1	E	24ECE615	PEC	Neural Networks and Deep Learning
2	E	24ECE625	PEC	Optical Communication and Networks
3	E	24ECE635	PEC	ASIC and SoC (System on Chip)
4	E	24ECE645	PEC	Virtual Instrumentation and LabVIEW
5	E	24ECE655	PEC	VLSI Testing and Verification

SEMESTER VII		PROFESSIONAL ELECTIVE III		
Sl No	Slot	Code	Category	Title
1	C	24ECE713	PEC	Advanced Microcontrollers (Ms-I)
2	C	24ECE723	PEC	Wireless Communication and 5G networks (Ms-II)
3	C	24ECE733	PEC	Speech and Audio Signal Processing (Ms-III)
4	C	24ECE743	PEC	Robotics
5	C	24ECE753	PEC	Low Power VLSI Design

<b>SEMESTER VIII PROFESSIONAL ELECTIVE IV</b>				
<b>Sl No</b>	<b>Slot</b>	<b>Code</b>	<b>Category</b>	<b>Title</b>
1	A	24ECE811	PEC	Biomedical Engineering
2	A	24ECE821	PEC	Theory of Error Control Coding
3	A	24ECE831	PEC	Embedded System Design for Automotive applications
4	A	24ECE841	PEC	Modern Communication Systems
5	A	24ECE851	PEC	Nanoelectronics

**LIST OF OPEN ELECTIVES**

<b>SEMESTER VII OPEN ELECTIVE I</b>			
<b>Sl No</b>	<b>Slot</b>	<b>Code</b>	<b>Title</b>
1	D	24EC0714	Wireless Adhoc and Sensor Networks
2	D	24EC0724	Mechatronics
3	D	24EC0734	Biomedical Instrumentation
4	D	24EC0744	Computer Architecture and Embedded Systems

<b>SEMESTER VIII OPEN ELECTIVE II</b>			
<b>Sl No</b>	<b>Slot</b>	<b>Code</b>	<b>Title</b>
1	B	24EC0812	Introduction to MEMS
2	B	24EC0822	Electronic Hardware for Engineers
3	B	24EC0832	Industrial Instrumentation
4	B	24EC0842	Computer Communication

<b>SEMESTER VIII OPEN ELECTIVE III</b>			
<b>Sl No</b>	<b>Slot</b>	<b>Code</b>	<b>Title</b>
1	C	24EC0813	Introduction to Computer Vision
2	C	24EC0823	Applied Communication Systems
3	C	24EC0833	Robotics and Automation
4	C	24EC0843	Cyber Security

**LIST OF MINOR COURSES**

<b>MINOR BASKET I - CIRCUITS</b>				
<b>Sl No</b>	<b>Slot</b>	<b>Code</b>	<b>y</b>	<b>Title</b>
1	M	24ECM309		Electronic Circuits
2	M	24ECM409		Digital Circuit Design
3	M	24ECM509		Embedded Systems
4	M	24ECM609		VLSI Circuits
5	M	24ECM709		PROJECT IN MINOR

<b>MINOR BASKET II - SIGNAL PROCESSING</b>				
<b>Sl No</b>	<b>Slot</b>	<b>Code</b>	<b>y</b>	<b>Title</b>
1	M	24ECM310		Basics of Signals and Systems
2	M	24ECM410		Introduction to Digital Signal Processing
3	M	24ECM510		Multimedia Processing and Forensics
4	M	24ECM610		Audio and Speech Processing
5	M	24ECM710		PROJECT IN MINOR

<b>MINOR BASKET III - COMMUNICATION</b>				
<b>Sl No</b>	<b>Slot</b>	<b>Code</b>	<b>y</b>	<b>Title</b>
1	M	24ECM311		Analog Communication
2	M	24ECM411		Fundamentals of Digital Communication
3	M	24ECM511		Computer Networks
4	M	24ECM611		Radar and Navigation
5	M	24ECM711		PROJECT IN MINOR

**LIST OF HONORS COURSES**

<b>HONOUR BASKET I - Medical Devices and Health Care Electronics</b>				
<b>Sl No</b>	<b>Slot</b>	<b>Code</b>	<b>y</b>	<b>Title</b>
1	H	24ECH409		Biosensors and Bioelectronics
2	H	24ECH509		Medical Device Design
3	H	24ECH609		Biomedical signal processing
4	H	24ECH709		Medical Imaging Systems
5	M	24ECH809		PROJECT IN HONORS

<b>HONOUR BASKET II - ARTIFICIAL INTELLIGENCE</b>				
<b>Sl No</b>	<b>Slot</b>	<b>Code</b>	<b>y</b>	<b>Title</b>
1	H	24ECH410		Artificial Intelligence
2	H	24ECH510		Natural Language Processing
3	H	24ECH610		Robotics and Artificial Intelligence
4	H	24ECH710		Deep Learning
5	M	24ECH810		PROJECT IN HONORS



### **RULES FOR ASSIGNING ACTIVITY POINTS**

To be successful professionals, students need more than just technical knowledge and skills; they must also possess excellent soft skills, leadership qualities, and team spirit. Additionally, they should have entrepreneurial capabilities and a strong commitment to society. To nurture these qualities, students are required to earn activity points through various extra-curricular and co-curricular activities. A minimum of 100 activity points is required to qualify for the B.Tech degree, and this is assessed on a pass/fail basis, contributing three credits towards the degree. These credits are mandatory for obtaining the B.Tech degree but are not included in the CGPA calculation.

For lateral entry students joining from the third semester, the requirement is 75 activity points. The points earned will be indicated in the consolidated academic statement. For students participating in NSS and NCC, points can be entered after the completion of the two-year program. All documental proof for awarding the activity points should be obtained, and the points are to be consolidated. The rules for assigning activity points are detailed in the following sections.

- National Initiatives
- Sports & Games
- Cultural Activities
- Professional Self Initiatives
- Entrepreneurship and Innovation
- Leadership & Management

The table below outlines the activities under each segment, the expected level of achievement, the corresponding activity points, the required evidence for assigning points, and the minimum duration for certain activities. Additional activities under these segments may be considered with approval from the Academic Council.

Activity Head	Sl. No	Activity	Achievement Levels and Assigned Activity Points					** Approval Document	Max. Points	Min. Duration of activity
			*Level	I	II	III	IV			
National Initiatives Participation	1	N C C	-	-	-	-	-	a/b	60	2 Year
	2	N S S	-	-	-	-	-	a/b	60	2 Year
	<p>For C certificate / outstanding performance supported by certification, additional marks up to 20 can be provided subjected to maximum limit of 80 points.</p> <p>Best NSS Volunteer Awardee (University level) / Participation in National Integration Camp/ Pre Republic-Day Parade Camp (South India), supported by certification, additional marks up to 10 can be provided subjected to maximum limit of 70 points</p> <p>Best NSS Volunteer Awardee (State / National level) / Participation in Republic Day Parade Camp / International Youth Exchange Programme, supported by certification, additional marks up to 20 can be provided subjected to maximum limit of 80 points</p>									
Sports & Games Participation	3	Sports:	8	15	25	40	60	a	60	1 Year
	4	Games	8	15	25	40	60	a	60	1 Year
		First Prize	10	10	10	20	20	Additional points can be provided for winning. The maximum limit for activity points is 60. But for Level IV and V winning, the maximum point limit is enhanced to 80.		
		Second Prize	8	8	8	16	16			
		Third Prize	5	5	5	12	12			
Cultural Activities Participation	5	Music	8	12	20	40	60	a	60	1 Year
	6	Performing arts	8	12	20	40	60	a	60	1 Year
	7	Literary arts	8	12	20	40	60	a	60	1 Year
		First Prize	10	10	10	20	20	Additional points can be provided for winning. The maximum limit for activity points is 60. But for Level IV and V winning, the maximum point limit is enhanced to 80.		
		Second Prize	8	8	8	16	16			
		Third Prize	5	5	5	12	12			

<b>Professional Self Initiatives</b>	8	Tech Fest, TechQuiz	10	20	30	40	50	a	50		
	9	MOOC with final assessment certificate	50					a	50		
	10	Competitions conducted by Professional Societies - (IEEE, IET, ASME, SAE, NASA etc.)	10	15	20	30	40	a	40		
	11	Attending Full time Conference/ Seminars / Exhibitions/ Workshop/ STTP conducted at IITs /NITs	15					a	30		
	11 a	Attending Full time Conference/ Seminars / Exhibitions/ Workshop/ STTP conducted at KTU or its affiliated institutes	6					a	12		
	12	Paper presentation/ publication at IITs /NITs	20					a	40		
	Additional 10 points for certificate of recognition.										
	12. a	Paper presentation/ publication at KTU or its affiliated institutes	8					a	16		
	Additional 2 points for certificate of recognition.										
	13	Poster Presentation at IITs /NITs	10					a	20		
	Additional 10 points for certificate of recognition.										
	13. a	Poster Presentation at KTU or its affiliated institutes	4					a	8		
	Additional 2 points for certificate of recognition.										

	14	Industrial Training/ Internship (atleast for 5 full days)	20	a/b	20	
	15	Industrial/ Exhibition visits	5	a/b/d	10	
	16	Foreign Language Skill (TOEFL/ IELTS/ BEC exams etc.)	50	a	50	
<b>Entrepreneurship and Innovation</b>	17	Start-up Company Registered legally	60	d	60	
	18	Patent-Filed	30	d	30	
	19	Patent - Published	35	d	60	
	20	Patent- Approved	50	d	60	
	21	Patent- Licensed	80	d	80	
	22	Prototype developed and tested	60	d	60	
	23	Awards for Products developed	60	d	60	
	24	Innovative technologies developed and used by industries/users	60	d	60	
	25	Got venture capital funding for innovative ideas/products.	80	d	80	
	26	Startup Employment (Offering jobs to two persons not less than Rs. 15000/- per month)	80	d	80	
	27	Societal innovations	50	d	50	

Leadership & Management			Core coordinat or	Sub coordinat or	Volunte er			
	28	Student Professional Societies (IEEE, IET, ASME, SAE, NASA etc.)	15	10	5	d	40	
	29	College Association Chapters (Mechanical, Civil, Electrical etc.)	15	10	5	d	40	
	30	Festival & Technical Events (College approved)	15	10	5	d	40	
	31	Hobby Clubs	15	10	5	d	40	
	32	Elected student representatives	30 (Chairman)	25 (Secretary)	15 (Other Council Members)	d	60	

# **SEMESTER-I**

## **SYLLABUS**



24MAT101	CALCULUS and LINEAR ALGEBRA						L	T	P	J	S	C	Year of Introduction 2024
							3	1	0	0	3	4	
<b>Preamble:</b>													
The course enables the students to understand basic concepts and tools of Calculus and Linear Algebra. The topics like Multivariable Calculus and Applications, Multiple integrals and applications, Vector Differentiation, Vector Integration and Linear Algebra are included. This course helps the learners in modeling and analyzing physical phenomena involving continuous changes of variables or parameters and has applications across all engineering domains.													
<b>Prerequisite:</b> Calculus of univariate functions and matrix theory.													
<b>Course Outcomes:</b> After the completion of the course the student will be able to													
<b>CO 1</b>	Apply the concept of partial derivatives to evaluate the extrema of two variable functions. [ <b>Apply level</b> ]												
<b>CO 2</b>	Use multiple integrals to find the area and volume of geometrical shapes, mass and center of gravity of plane laminas. [ <b>Apply level</b> ]												
<b>CO 3</b>	Utilize vector calculus techniques to solve problems related to vector fields in various disciplines. [ <b>Apply level</b> ]												
<b>CO 4</b>	Apply appropriate techniques such as Green's theorem, Stokes' theorem and divergence theorem to evaluate vector integrals for different types of regions and surfaces. [ <b>Apply level</b> ]												
<b>CO 5</b>	Use the Gauss elimination method to solve given systems of linear equations and to determine whether a matrix is diagonalizable. [ <b>Apply level</b> ]												
<b>CO - PO MAPPING</b>													
CO	PO1	PO2	PO3	PO4	PO5	PO6	PO7	PO8	PO9	PO10	PO11	PO12	
CO 1	✓	✓			✓				✓			✓	
CO 2	✓	✓			✓				✓			✓	
CO 3	✓	✓			✓				✓			✓	
CO 4	✓	✓			✓				✓			✓	
CO 5	✓	✓			✓				✓			✓	
<b>Assessment Pattern</b>													
Bloom's Category	Continuous Assessment Tools			End Semester Examination									
	Test 1	Test 2	Other tools										
Remember	✓	✓	✓	✓									
Understand	✓	✓	✓	✓									
Apply	✓	✓	✓	✓									
Analyse													
Evaluate													
Create													

<b>Mark Distribution of CIA</b>					
<b>Course Structure [L-T-P-J]</b>	<b>Attendance</b>	<b>Theory [L- T]</b>			<b>Total Marks</b>
		<b>Assignment</b>	<b>Test-1</b>	<b>Test-2</b>	
<b>3-1-0-0</b>	5	15	10	10	<b>40</b>
<b>Total Mark distribution</b>					
<b>Total Marks</b>	<b>CIA (Marks)</b>	<b>ESE (Marks)</b>		<b>ESE Duration</b>	
100	40	60		3 hours	

**End Semester Examination [ESE]: Pattern**

<b>PATTERN</b>	<b>PART A</b>	<b>PART B</b>	<b>ESE Marks</b>
PATTERN 1	10 Questions, each question carries 2 marks  Marks: (2x10 =20 marks)	2 questions will be given from each module, out of which 1 question should be answered. Each question can have a maximum of 2 sub divisions.  Each question carries 8 marks.  Marks: (5x8 = 40 marks) Time: 3 hours	60
	Total Marks: 20	Total Marks: [5x8 = 40 marks]	

**SYLLABUS****MODULE I : (Multivariable Calculus and Applications)**

Partial derivatives, Partial derivatives of functions of two variables, The partial derivative functions, Partial derivatives viewed as rates of change and slopes, Implicit partial differentiation, Partial derivatives of functions with more than two variables, Higher-order partial derivatives, Equality of mixed partials, Differentiability, Differentials, Local linear approximations, The chain rule, Chain rules for partial derivatives, Other versions of the chain rule, Implicit differentiation, Maxima and minima of functions of two variables - Extrema, Finding relative extrema, The second partials test.

**MODULE II : (Multiple integrals and applications)**

Double integrals (Cartesian), Double integrals over nonrectangular regions, Reversing the order of integration, Change of coordinates (Cartesian to polar), Finding area and volume using double integrals, Application of multiple integrals-mass and center of gravity of inhomogeneous laminas using double integral. Triple integrals, volume calculated as triple integral (exclude problems of intersection of solids), and triple integral in cylindrical coordinates.

**MODULE III : (Vector Differentiation)**

Vector valued functions of single variable, derivative of vector function and geometrical interpretation, motion along a curve –velocity, speed and acceleration. Concept of scalar and vector fields, Gradient and its properties, directional derivative, divergence and curl, Line integrals of vector fields, work as line integral, Conservative vector fields, independence of path and potential function (results without proof).

**MODULE IV : (Vector Integration)**

Green's Theorem (for simply connected domains, without proof) and applications to evaluating line integrals and finding areas. Divergence theorem (without proof) and its

applications to flux integrals, Stokes' theorem (without proof) and its applications to finding line integrals of vector fields and work done. Evaluation of Surface integral using Stokes' theorem.

### MODULE V : (Linear Algebra)

Systems of linear equations, Solution by Gauss elimination, row echelon form and rank of a matrix, fundamental theorem for linear systems (homogeneous and non-homogeneous, without proof), eigenvalues and eigenvectors, Properties of eigenvalues and eigenvectors, Diagonalization of matrices.

#### Text books

1. H. Anton, I. Biven, S. Davis, "Calculus", Wiley, 10th edition, 2015.
2. Erwin Kreyszig, Advanced Engineering Mathematics, 10<sup>th</sup> Edition, John Wiley & Sons, 2016.

#### Reference books

1. J. Stewart, Essential Calculus, Cengage, 2nd edition, 2017
2. G.B. Thomas and R.L. Finney, Calculus and Analytic geometry, 9<sup>th</sup> Edition, Pearson, Reprint, 2002.
3. Peter V. O'Neil, Advanced Engineering Mathematics, Cengage, 7th Edition, 2012
4. Veerarajan T., Engineering Mathematics for first year, Tata McGraw-Hill, New Delhi, 2008.
5. B.S. Grewal, Higher Engineering Mathematics, Khanna Publishers, 36 Edition, 2010.
6. Dr. Joydeep Dutta, Calculus of Several Real Variables, IIT Kanpur, [NPTEL], <https://nptel.ac.in/courses/111104125> (Relevant sections)
7. Prof. Gilbert Strang, Linear Algebra [MITOPENCOURSEWARE]
8. <https://ocw.mit.edu/courses/18-06-linear-algebra-spring-2010/> (Relevant sections)

### COURSE CONTENTS AND LECTURE SCHEDULE

No.		No. of Hours[ 45 hours]
<b>MODULE 1</b> [9 hours]		
1.1	Partial derivatives, Partial derivatives of functions of two variables	1
1.2	Implicit partial differentiation, Partial derivatives of functions with more than two variables	1
1.3	Higher-order partial derivatives, Equality of mixed partials	1
1.4	Differentials	1
1.5	Local Linear approximations	1
1.6	Chain rule, Implicit differentiation	1
1.7	Total derivative	1
1.8	Maxima and minima of functions of two variables - Extrema, Finding relative extrema, The second partials test.	1
1.9	Maxima and minima of functions of two variables(continued)	1
<b>MODULE II</b> [10 hours]		
2.1	Double integrals (Cartesian)-evaluation	1
2.2	Double integrals(continued)	1
2.3	Change of order of integration in double integrals	1
2.4	Change of coordinates (Cartesian to polar)	1
2.5	Finding areas and volumes	1
2.6	Finding areas and volumes(continued)	1
2.7	Mass and center of gravity of plane laminas	1
2.8	Triple integrals,	1

2.9	Volume calculated as triple integral (exclude problems of the intersection of solids)	1
2.10	Triple integral in cylindrical coordinates	1
<b>MODULE III</b> [9 hours]		
3.1	Vector valued function of a scalar variable	1
3.2	Derivative of vector valued function of scalar variable -geometrical meaning	1
3.3	Motion along a curve-speed , velocity, acceleration	1
3.4	Gradient and its properties	1
3.5	Directional derivative	1
3.6	Divergent and curl	1
3.7	Line integrals with respect to arc length, line integrals of vector fields.	1
3.8	Work done as line integral	1
3.9	Conservative vector field, independence of path, potential function	1
<b>MODULE IV</b> [9 hours]		
4.1	Green's theorem and its applications	1
4.2	Green's theorem and its applications(continued)	1
4.3	Green's theorem and its applications(continued)	1
4.4	Divergence theorem and applications	1
4.5	Divergence theorem and applications(continued)	1
4.6	Divergence theorem and applications(continued)	1
4.7	Stokes theorem and applications	1
4.8	Stokes theorem and applications(continued)	1
4.9	Stokes theorem and applications(continued)	1
<b>MODULE V</b> [8 hours]		
5.1	Systems of linear equations, Solution by Gauss elimination	1
5.2	Row echelon form	1
5.3	Finding rank from row echelon form	1
5.4	Fundamental theorem for linear systems (homogeneous and non-homogeneous, without proof)	1
5.5	Eigenvalues and eigenvectors	1
5.6	Properties of eigenvalues and eigenvectors	1
5.7	Diagonalization of matrices	1
5.8	Diagonalization of matrices(continued)	1

**CO Assessment Questions**

1	<p>1. A manufacturer makes two models of an item, standard and deluxe. It costs Rs. 40 to manufacture the standard model and Rs. 60 for the deluxe. A market research firm estimates that if the standard model is priced at rupees <math>x</math> and the deluxe at rupees <math>y</math> , then the manufacturer will sell <math>500(y - x)</math> of the standard items and <math>45,000 + 500(x - 2y)</math> of the deluxe each year. How should the items be priced to maximize the profit?</p> <p>2. Determine the dimension of the rectangular box open at the top, having a volume 32 cubic ft and requiring the least amount of material for its construction.</p>
---	---

	<p>3. The temperature <math>T(x,y,z)</math> at any point <math>(x, y, z)</math> in space is given by <math>T(x,y,z) = x^2 + y^2 + z^2</math>. Find the differential <math>dT</math> at a point <math>(a, b, c)</math>, and use it to approximate the change in temperature when the coordinates change by small amounts <math>\delta x, \delta y</math>, and <math>\delta z</math>.</p> <p>4. Use a CAS(MATLAB/SCILAB/Python) to generate a contour plot of <math>f(x,y) = 2y^2x - yx^2 + 4xy</math> for <math>-5 \leq x \leq 5</math> and <math>-5 \leq y \leq 5</math>, and use the plot to approximate the locations of all relative extrema and saddle points in the region. Check your answer using calculus, and identify the relative extrema as relative maxima or minima.</p> <p>5. <b>Team Work</b> : Use the method of least squares(refer exercise 13.8 in text 1) to find the values of <math>m</math> and <math>b</math> in the regression line <math>y=mx+b</math> that best fits the data <math>(x_1, y_1), (x_2, y_2), \dots, (x_n, y_n)</math>. The team has to make a presentation elaborating the solution and illustrating the method on any data set (using any programming language).</p>
2	<p>1. Consider a thin metal plate that occupies the triangular region <math>R</math> in the <math>xy</math>-plane with vertices at <math>(0, 0), (2, 0)</math>, and <math>(0, 3)</math>. The temperature on the plate is given by <math>T(x,y) = x^2 + y^2</math>, where <math>x</math> and <math>y</math> are the coordinates of a point. Find the average temperature over the region <math>R</math>.</p> <p>2. A water tank has the shape of a hemisphere with a radius of 4 meters. The tank is filled with water up to a height of <math>h</math> meters. Find the total weight of the water in the tank using a double integral, assuming the density of water is constant.</p> <p>3. Find the mass and centre of gravity of a triangular lamina with vertices <math>(0,0), (2,1), (0,3)</math> if the density function is <math>f(x, y) = x + y</math>.</p> <p>4. Use a CAS(MATLAB/SCILAB/Python) to approximate the intersections of the curves <math>y = \sin x</math> and <math>y = x/2</math>, and then approximate the volume of the solid in the first octant that is below the surface <math>z = \sqrt{1 + x + y}</math> and above the region in the <math>xy</math>-plane that is enclosed by the curves.</p> <p>5. <b>Team Work</b> : The following initial steps can be used to express a triple integral over a solid <math>G</math> as an iterated triple integral: First project <math>G</math> onto one of the coordinate planes to obtain a region <math>R</math>, and then project <math>R</math> onto one of the coordinate axes. Describe how you would use these steps to find the limits of integration. Illustrate your discussion with an example using any software. The team has to make a presentation elaborating the procedure.</p>
3	<p>1. A heat-seeking particle is located at the point <math>(2, 3)</math> on a flat metal plate whose temperature at a point <math>(x, y)</math> is <math>T(x,y) = 10 - 8x^2 - 2y^2</math>. Find an equation for the trajectory of the particle if it moves continuously in the direction of maximum temperature increase.</p> <p>2. A vector field <math>F(x, y, z) = (y, x, 2z)</math> represents the velocity of a fluid flow in three-dimensional space. Determine the divergence and curl of <math>F</math>, and interpret the physical meaning of these vector operations.</p> <p>3. A vector field <math>F(x,y,z) = (x^2, xy, yz)</math> represents a force field in three-dimensional space. Show that <math>F</math> is conservative and find a potential function for <math>F</math>. Also, evaluate the work done by <math>F</math> along a curve <math>C</math> from point <math>A(1, 2, 0)</math> to point <math>B(3, 1, 4)</math>.</p>

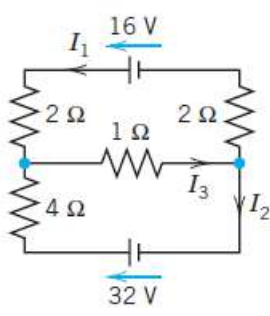
	<p>4. Visualize any five vector fields relevant to your domain using CAS(MATLAB/SCILAB/Python).</p> <p>5. <b>Team Work</b> : Suppose that C is a circle in the domain of a conservative nonzero vector field in the xy-plane whose component functions are continuous. Explain why there must be at least two points on C at which the vector field is normal to the circle. Also, illustrate using figures drawn in any software. Does the result remain true if the circle C is replaced by a square? Explain. The team has to make a presentation elaborating the solution.</p>
<p>4</p>	<p>1. Suppose we have a region R in the xy-plane bounded by a simple closed curve C. The temperature distribution in this region is given by the function <math>T(x,y) = 2x^2 - 3y^2</math>. Calculate the total heat flux across the boundary curve C using Green's theorem.</p> <p>2. Find the outward flux of the vector field <math>F(x,y,z) = z\hat{k}</math> across the sphere <math>x^2 + y^2 + z^2 = a^2</math> using divergence theorem.</p> <p>3. Calculate the work done by force field <math>F(x,y,z) = 2xi + 3yj + 4zk</math> where C is the curve defined by the ellipse <math>\frac{x^2}{9} + \frac{y^2}{4} = 1</math> in the counterclockwise direction using Stokes' Theorem.</p> <p>4. Use a CAS(MATLAB/SCILAB/Python) to verify Green's Theorem for the function <math>F = e^y\mathbf{i} + ye^x\mathbf{j}</math> where          (a) C is the circle <math>x^2 + y^2 = 1</math>          (b) C is the boundary of the region enclosed by <math>y = x^2</math> and <math>x = y^2</math>.</p> <p>5. <b>Team Work</b> : Explain with graphics how a rolling planimeter is used to calculate the area of a region. Describe the relationship between these devices and Green's Theorem. Illustrate an example. The team has to make a presentation elaborating the solution.</p>
<p>5</p>	<p>1. Using Kirchoff's laws and showing the details, find the currents:</p> <div style="text-align: center;">  </div> <p>2. Find the growth rate in the Leslie model (see Example 3. Sec8.2 Text2) with the matrix as given <math>\begin{bmatrix} 0 &amp; 3.45 &amp; 0.60 \\ 0.9 &amp; 0 &amp; 0 \\ 0 &amp; 0.45 &amp; 0 \end{bmatrix}</math>.</p> <p>3. A system is represented by the state equation <math>\begin{bmatrix} \frac{dx_1}{dt} \\ \frac{dx_2}{dt} \end{bmatrix} = \begin{bmatrix} 0 &amp; 1 \\ -4 &amp; -5 \end{bmatrix} \begin{bmatrix} x_1 \\ x_2 \end{bmatrix} + \begin{bmatrix} 0 \\ 1 \end{bmatrix} u</math>. Show that it is controllable.</p> <p>4. In circuit theory a set of linear equations with electrical components such</p>

as resistance inductance capacitors current voltage etc. Identify a problem solved using matrix algebra and solve it using CAS(MATLAB/SCILAB/Python).

5. **Team Work** : Identify five application-oriented problems from your domain and its solution. Give a PPT illustrating the relevance of the problem.



24PYP102	ENGINEERING PHYSICS (FOR CIRCUIT BRANCHES)						L	T	P	J	S	C	Year of Introduction
							2	1	2	0	4	4	2024
<p><b>Preamble:</b> Enable the students to enhance the fundamental knowledge in physics and its applications relevant to various streams of Engineering and Technology. The topics like Oscillations and Wave Motion, Wave Optics, Quantum Mechanics for Engineers, Introduction to Electromagnetic Theory and Introduction to Solids are covered in the syllabus. This helps the learners to explore the advanced concepts in physics and to do interdisciplinary research.</p> <p><b>Prerequisite:</b> Higher secondary level Physics and Mathematics.</p> <p><b>Course Outcomes:</b> After the completion of the course the student will be able to</p>													
<b>CO1</b>	Interpret the characteristics of mechanical and electrical oscillators. [Apply level]												
<b>CO2</b>	Demonstrate the concepts of interference and diffraction for the determination of wavelength of unknown sources. [Apply level]												
<b>CO3</b>	Use the basic principles of quantum mechanics to determine the energy eigen values and eigen functions of particle in a box. [Apply level]												
<b>CO4</b>	Apply the Maxwell's equations in estimating the speed of light. [Apply level]												
<b>CO5</b>	Use low power lasers in doing optical and fibre optical experiments. [Apply level]												
<b>CO - PO MAPPING</b>													
CO	PO1	PO2	PO3	PO4	PO5	PO6	PO7	PO8	PO9	PO10	PO11	PO12	
<b>CO1</b>	3	3			3			3	3	3		3	
<b>CO2</b>	3	3			3			3	3	3		3	
<b>CO3</b>	3	3			3							3	
<b>CO4</b>	3												
<b>CO5</b>	3							3	3	3			
<b>Assessment Pattern for Theory component</b>													
Bloom's Category	Continuous Assessment Tools			End Semester Examination									
	Test 1	Test 2	Other tools										
Remember	✓	✓	✓	✓									
Understand	✓	✓	✓	✓									
Apply	✓	✓	✓	✓									
Analyse													



Evaluate				
Create				
<b>Assessment Pattern for Lab component</b>				

Bloom's Category	Continuous Assessment Tools	
	Class work	Test1
Remember		
Understand	✓	✓
Apply	✓	✓
Analyse		
Evaluate		
Create		

**Mark Distribution of CIA**

Course Structure [L-T-P-J]	Attendance	Theory [L- T]			Practical [P]		Total Marks
		Assignment	Test-1	Test-2	Class work	Lab Exam	
<b>2-1-2-0</b>	5	10	12.5	12.5	10	10	<b>60</b>

**Total Marks distribution**

Total Marks	CIA (Marks)	ESE (Marks)	ESE Duration
100	60	40	2.5 hours

**End Semester Examination [ESE]: Pattern**

PATTERN	PART A	PART B	ESE Marks
PATTERN 2		<p>2 questions will be given from each module, out of which 1 question should be answered. Each question can have a maximum of 2 sub divisions.</p> <p>Each question carries 8 marks.</p> <p>Marks: (5x 8 = 40 marks)</p> <p>Time: 2.5 hours</p>	40
	Total Marks: 0	Total Marks:[5x8= 0marks]	

## SYLLABUS

### **MODULE I : Oscillations and Wave Motion (7 hours)**

#### **Simple harmonic motion, damped and forced simple harmonic oscillator**

Damped harmonic oscillator: derivation of equation of motion and its solution, under damped oscillators; energy decay in damped harmonic oscillator, Quality factor (qualitative)- Forced harmonic oscillator: equation of motion and its solution (No derivation), Amplitude resonance - Electrical analogy of mechanical oscillators  
- Numerical problems.

#### **Transverse waves in one dimension**

Transverse and Longitudinal waves - Transverse waves on a stretched string; the wave equation on a string, derivation for the velocity and frequency of transverse vibrations on a stretched string- Numerical problems.

### **MODULE II : Wave Optics (7 hours)**

#### **Interference of light by amplitude splitting**

Interference of reflected light in thin films; Interference in thin films (Cosinelaw); Derivation of the conditions of constructive and destructive Interference  
- Air Wedge; Determination of thickness of a thin wire - Antireflection coatings  
- Numerical problems.

#### **Diffraction of light**

Fresnel and Fraunhofer classes of diffraction - Diffraction grating - Grating equation - Rayleigh's criterion for limit of resolution - Resolving power of a grating with expression (no derivation), Comparison of interference and diffraction - Numerical problems.

### **MODULE III : Quantum Mechanics for Engineers (8 hours)**

#### **Wave nature of particles and the Schrodinger equation**

Wave-Particle dualism; de Broglie hypothesis, de-Broglie wavelength - Wave function; Admissibility conditions, Physical significance, Probability density, Normalization condition - Time dependent Schrödinger wave equation - Time independent Schrödinger wave equation.

#### **Applying the Schrodinger equation**

Particle in a one-dimensional box; Energy Eigen values and normalized wave function, concept of quantum number, Quantum mechanical tunnelling (qualitative)  
- Numerical problems.

### **MODULE IV : Introduction to Electromagnetic Theory (7 hours)**

Physics of gradient, divergence and curl - Gauss's divergence theorem and Stoke's theorem- Equation of continuity, Deduction of Maxwell's equations in vacuum - Electromagnetic waves: Electromagnetic wave equation in free space, velocity of Electromagnetic waves in free space, Poynting's theorem (Qualitative) - Numerical problems.

**MODULE V: Introduction to Solids (7 hours)**

Pauli's exclusion principle - Particle in a three-dimensional box; expression for Energy Eigen value and normalized wave function - Concept of quantum state and degeneracy - The density of states; Expression for density of states for a spinless particle, density of states for an electron. Effective mass concept (qualitative). Numerical problems.

**Text books**

1. M.N.Avadhanulu, P.G.Kshirsagar, TVS Arun Murthy "A Text book of Engineering Physics", S.Chand & Co., Revised Edition 2019.
2. H.K.Malik, A.K. Singh, "Engineering Physics" McGraw Hill Education, Second Edition 2017.

**Reference books**

1. Arthur Beiser, "Concepts of Modern Physics", Tata McGraw Hill Publications, 6th Edition 2003.
2. D. .K. Bhattacharya, Poonam Tandon, "Engineering Physics", Oxford University Press, 2015.
3. Md.N.Khan & S.Panigrahi "Principles of Engineering Physics 1&2", Cambridge University Press, 2016.
4. Aruldas G., "Engineering Physics", PHI Pvt. Ltd., 2015.
5. Ajoy Ghatak, "Optics", Mc Graw Hill Education, Sixth Edition, 2017.
6. Premlet B., "Advanced Engineering Physics", Phasor Books, 11th edition, 2021.
7. I. Dominic and. A. Nahari, "A Text Book of Engineering physics", Owl Books Publishers, Revised edition, 2016.
8. H.D Young and R.A Freedman, University Physics with Modern Physics 2020, 15th Edition, Pearson, USA.
9. Introduction to solid state devices, B Premlet, Phasor Books.
10. Griffiths "Introduction to Electrodynamics" 4th Edition, Pearson.

**COURSE CONTENTS AND LECTURE SCHEDULE**

No.		No. of Hours[36]
<b>MODULE 1: Oscillations and Wave Motion (7 hours)</b>		
1.1	Simple harmonic motion, damped and forced simple harmonic oscillator. Damped harmonic oscillator: derivation of equation of motion and its solution, under damped oscillators; energy decay in damped harmonic oscillator.	1
1.2	Quality factor (qualitative), Numerical problems.	1
1.3	Forced harmonic oscillator: equation of motion and its solution (No derivation).	1
1.4	Amplitude resonance, Numerical problems	1
1.5	Electrical analogy of mechanical oscillators- Numerical problems.	1

1.6	Transverse waves in one dimension Transverse and Longitudinal waves - Transverse waves on a stretched string; the wave equation on a string, derivation for the velocity and frequency of transverse vibrations on a stretched string.	1
1.7	Numerical problems.	1
<b>MODULE II: Wave Optics (7 hours)</b>		
2.1	Interference of light by amplitude splitting Interference of reflected light in thin films; Interference in thin films (Cosine law).	1
2.2	Derivation of the conditions of constructive and destructive Interference, Numerical problems	1
2.3	Air Wedge; Determination of thickness of a thin wire	1
2.4	Antireflection coatings - Numerical problems.	1
2.5	Diffraction of light Fresnel and Fraunhofer classes of diffraction - Diffraction grating -Grating equation.	1
2.6	Rayleigh's criterion for limit of resolution - Resolving power of a grating with expression (no derivation), Numerical problems.	1
2.7	Comparison of interference and diffraction, Numerical problems.	1
<b>MODULE III: Quantum Mechanics for Engineers (8 hours)</b>		
3.1	Wave nature of particles and the Schrodinger equation Wave-Particle dualism; de Broglie hypothesis, de-Broglie wavelength, Numerical problems.	1
3.2	Wave function; Admissibility conditions, Physical significance, Probability density, Normalization condition.	1
3.3	Time dependent Schrödinger wave equation.	1
3.4	Time independent Schrödinger wave equation (no derivation).	1
3.5	Applying the Schrodinger equation Particle in a one-dimensional box; Energy Eigen values and normalized wave function, Numerical problems.	1
3.6	Concept of quantum numbers.	1
3.7	Quantum mechanical tunnelling (qualitative).	1
3.8	Numerical problems.	1
<b>MODULE IV: Introduction to Electromagnetic Theory (7 hours)</b>		
4.1	Physics of gradient, divergence and curl, Numerical problems.	1
4.2	Gauss's divergence theorem and Stoke's theorem- Equation of continuity.	1
4.3	Deduction of Maxwell's equations in vacuum (first two equations).	1

4.4	Deduction of Maxwell's equations in vacuum (third and fourth equations).	1
4.5	Electromagnetic waves: Electromagnetic wave equation in free space.	1
4.6	Velocity of Electromagnetic waves in free space, Numerical problems.	1
4.7	Poynting's theorem (Qualitative) - Numerical problems.	1
<b>MODULE V: Introduction to Solids (7 hours)</b>		
5.1	Pauli's exclusion principle.	1
5.2	Particle in a three-dimensional box.	1
5.3	Expression for Energy Eigen value and normalized wavefunction.	1
5.4	Concept of quantum state and degeneracy.	1
5.5	The density of states; Expression for density of states for a spinless particle.	1
5.6	Density of states for an electron.	1
5.7	Effective mass concept (qualitative). Numerical problems.	1

#### **LESSON PLAN FOR LAB COMPONENT**

<b>No.</b>	<b>Topic</b>	<b>No. of Hours</b>	<b>Experiment</b>
1	Oscillations	4	1. Resonance phenomenon in mechanical oscillators. 2. LCR Circuit – Forced and damped harmonic oscillations.
2	Waves	4	1. Melde's string apparatus- Measurement of frequency in the transverse mode. 2. Melde's string apparatus- Measurement of frequency in the longitudinal mode.
3	Interference	4	1. Wave length measurement of a monochromatic source of light using Newton's Rings method. 2. Determination of diameter of a thin wire or thickness of a thin strip of paper using air wedge method.
4	Diffraction	4	1. Determination of resolving power of a plane transmission grating. 2. Determination of the wavelength of laser source using diffraction grating.

5	Quantum Mechanics	4	<ol style="list-style-type: none"> <li>1. Determination of the particle size of lycopodium powder.</li> <li>2. Numerical demonstration of the discrete energy levels and wavefunctions using Schrodinger equation. (e.g., Particle in a box problem)</li> </ol>
6	Electromagnetic Theory	4	<ol style="list-style-type: none"> <li>1. Determine the characteristics of EM waves using Hertz experiment.</li> <li>2. Determination of Numerical aperture of optic fiber using Laser.</li> </ol>
(Any 6 experiments to be completed)			

### CO Assessment Questions

1	<ol style="list-style-type: none"> <li>1) Compute the frequency and Quality factor for an LCR circuit with <math>L = 2\text{mH}</math>, <math>C = 5\mu\text{F}</math> and <math>R = 0.2\Omega</math>.</li> <li>2) Frame any five numerical problems on oscillations with different difficulty levels and solve them.</li> <li>3) Identify the applications of the theory of oscillations in the field of engineering and prepare a Power Point presentation on any one system which failed in applying the theory of damped or forced oscillation. (Eg: Failed due to damping, resonance etc.)</li> <li>4) Determine experimentally the characteristics of an LCR oscillator.</li> </ol>
2	<ol style="list-style-type: none"> <li>1) Light of wavelength <math>6000\text{\AA}</math> falls normally on a wedge-shaped film. The two plates touch at one end and are separated at 10 cm from that end by a wire. If the bandwidth of interference pattern is 0.05mm, find the diameter of the wire.</li> <li>2) Design any three numerical problems on Interference and implement these using any one programming language and submit the source code and output.</li> <li>3) Write a brief report on the limitations of any one optical instrument used in engineering systems. Determine experimentally the wavelength of a laser source using diffraction grating.</li> </ol>
3	<ol style="list-style-type: none"> <li>1) Apply the appropriate Schrodinger equation and compute the first three energy eigen values and wave functions of a particle trapped inside a well.</li> <li>2) Make a video demonstrating any one Engineering System in which classical physics failed to give a perfect design and was designed with the aid of Quantum Mechanics.</li> </ol>
4	<ol style="list-style-type: none"> <li>1) Determine the velocity of Electromagnetic waves in free space using Maxwell's equations.</li> <li>2) Create a quiz based on numerical problems from electromagnetic theory using appropriate tool.</li> </ol>

5

- 1) Determine experimentally the wavelength of a standard laser source using diffraction grating arrangement.
- 2) Determine experimentally the NA of an optic fibre cable.

<b>24EST104</b>	<b>FUNDAMENTALS OF ELECTRICAL ENGINEERING</b>	<b>L</b>	<b>T</b>	<b>P</b>	<b>J</b>	<b>S</b>	<b>C</b>	<b>Year of Introduction</b>
		<b>3</b>	<b>0</b>	<b>0</b>	<b>0</b>	<b>3</b>	<b>3</b>	<b>2024</b>

**Preamble:**

To provide the students with fundamental knowledge in the field of Electrical Engineering. This course will enable the students to analyze electrical and magnetic circuits. The students will be able to choose appropriate electric machines for various applications.

**Prerequisite:** Nil

**Course Outcomes:** After the completion of the course the student will be able to

<b>CO 1</b>	Solve DC electrical circuits using Circuit laws. (Apply level)
<b>CO 2</b>	Solve simple magnetic circuits (Apply level)
<b>CO 3</b>	Analyze simple A.C. electrical circuits (Analyse level)
<b>CO 4</b>	Identify the benefits of three-phase systems for industrial electrical applications (Understand level)
<b>CO 5</b>	Explain the principle of operation of electrical machines (Understand level)

**CO - PO MAPPING**

<b>CO</b>	<b>PO1</b>	<b>PO2</b>	<b>PO3</b>	<b>PO4</b>	<b>PO5</b>	<b>PO6</b>	<b>PO7</b>	<b>PO8</b>	<b>PO9</b>	<b>PO10</b>	<b>PO11</b>	<b>PO12</b>
<b>CO 1</b>	<b>3</b>	<b>1</b>										
<b>CO 2</b>	<b>3</b>	<b>2</b>										
<b>CO 3</b>	<b>3</b>				<b>2</b>			<b>2</b>	<b>1</b>			
<b>CO 4</b>	<b>3</b>											
<b>CO 5</b>	<b>3</b>											

**Assessment Pattern**

<b>Bloom's Category</b>	<b>Continuous Assessment Tools</b>			<b>End Semester Examination</b>
	<b>Test 1</b>	<b>Test 2</b>	<b>Other tools</b>	
Remember	✓	✓	✓	✓
Understand	✓	✓	✓	✓
Apply	✓	✓	✓	✓
Analyse			✓	
Evaluate				
Create				

**Mark Distribution of CIA**

<b>Course Structure [L-T-P-J]</b>	<b>Attendance</b>	<b>Theory [L- T]</b>			<b>Total Marks</b>
		<b>Assignment</b>	<b>Test-1</b>	<b>Test-2</b>	
<b>3-0-0-0</b>	<b>5</b>	<b>15</b>	<b>10</b>	<b>10</b>	<b>40</b>



<b>Total Mark distribution</b>			
<b>Total Marks</b>	<b>CIA (Marks)</b>	<b>ESE (Marks)</b>	<b>ESE Duration</b>
100	40	60	3 hours
<b>End Semester Examination [ESE]: Pattern</b>			
<b>PATTERN</b>	<b>PART A</b>	<b>PART B</b>	<b>ESE Marks</b>
<b>PATTERN 1</b>	10 Questions, each question carries 2 marks  Marks: (2x10 =20 marks)	2 questions will be given from each module, out of which 1 question should be answered. Each question can have a maximum of 2 sub divisions.  Each question carries 8 marks. Marks: (5x8 = 40 marks) Time: 3 hours	<b>60</b>
	Total Marks: 20	Total Marks: [5x8 = 40 marks]	

<b>SYLLABUS</b>
<b>MODULE I: Introduction to electrical and magnetic circuits</b>
Introduction: Importance of Electrical Engineering in day-to-day life, types of Electrical elements - Ideal and practical Sources.
D. C. Circuits: Ohm's Law and Kirchhoff's Laws; Loop current; Steady state analysis with independent sources; Power and energy; Star- Delta conversion (Analysis of resistive networks only).
Magnetic circuits: MMF, field strength, flux density, reluctance, energy stored in magnetic circuits, Simple problems in series magnetic circuits.
Electromagnetism: Faradays Laws, Lenz's Law, Fleming's Rules, Statically and dynamically induced EMF; Concepts of self-inductance, mutual inductance and coefficient of coupling. Simple numerical problems.
<b>MODULE II: Single Phase AC Circuits</b>
Single Phase system: Generation of sinusoidal voltage. Series Circuits: Common signals and waveforms (Sine, Square, Triangle), RMS and Average value, form factor and peak factor of AC waveforms, Impedance of series circuits (RL, RC and RLC circuits). Phasor diagram of series circuits; Real, reactive and apparent power, power factor, Power triangle, Numerical Problems.
<b>MODULE III: Three Phase System</b>

Three Phase System: Generation of three phase voltages- advantages of three phase systems, star and delta connection, three wire and four wire systems, relation between line and phase voltages, line and phase currents. Expressions for power in three phase circuits; definition of phase sequence, balanced supply and balanced load; Relationship between line and phase values of balanced star and delta connections; Power in balanced three phase circuits. Numerical Problems.

#### **MODULE IV: DC Machines and Transformers**

DC Machines: Working principle of DC generator - types and constructional features - EMF equation of generator - Numerical Problems.

DC motor: Working principle - Significance of Back EMF - torque equation - types - characteristics (series and Shunt motors only) and applications - necessity of a starter for DC motor - Numerical Problems.

Transformer: Principle of operation and construction of single-phase transformers (core and shell types) - emf equation, losses.

#### **MODULE V: AC Machines and Energy storage**

Three Phase Induction Motors: Concept of rotating magnetic field - principle of operation, types and constructional features - Slip and its significance - applications of squirrel cage and slip ring motors - Necessity of a starter - star-delta starter.

Energy storage devices: fundamentals of batteries - types - primary - Secondary batteries, Lead-Acid Batteries, Lithium-Ion Batteries - characteristics-advantages - disadvantages

#### **Text books**

1. Hughes, Electrical Technology, Pearson, 10th Edition, 2011.
2. Fitzgerald and Higginbotham, Basic Electrical Engineering, McGraw Hill Inc, 1981.
3. D.P. Kothari and I.J. Nagrath, Basic Electrical Engineering, 3rd Edition, TMH, 2009
4. Basic Electrical Engineering, D. C. Kulshreshtha, McGraw-Hill Education, Revised first edition, 2019.

#### **Reference books**

1. W. H. Hayt, Jr J. E. Kemmerly and S. M. Durbin, Engineering Circuit Analysis, 7th Edn TMH, 2010.
2. Electrical Engineering Fundamental, Vincent Del Toro, Prentice Hall, New Delhi.
3. Fundamentals of Electrical Engineering and Electronics, B.L. Theraja, S Chand and Company, Reprint Edition 2013.
4. Principles Electrical Engineering and Electronics, V.K Mehata, Rohit Mehta, S Chand and Company, 2nd edition, 2015.
5. M.S. Sukhija and T.K. Nagsarkar, Basic Electrical and Electronics Engineering, Oxford University Press, 2012.
6. S. B. Lal Seksena and Kaustuv Dasgupta, "Fundamentals of Electrical Engineering", Cambridge University Press.
7. NPTEL course on Basic Electrical Technology, Prof. G. D. Roy, IIT Kharagpur.

<b>COURSE CONTENTS AND LECTURE SCHEDULE</b>		
No.		No. of Hours (36 Hours)
<b>MODULE 1</b>		
1.1	Importance of Electrical Engineering in day-to-day life, types of Electrical elements, Ideal and practical Sources	1
1.2	Ohm's Law and Kirchhoff's Laws; Loop current method	1
1.3	Steady state analysis with independent sources; Power and energy; Star-Delta conversion (Analysis of resistive networks only)	1
1.4	Numerical problems on topic 1.3	1
1.5	MMF, field strength, flux density, reluctance, energy stored in magnetic circuits, Simple problems in series magnetic circuits	1
1.6	Faradays Laws, Lenz's; Law, Fleming's Rules, Statically & dynamically induced EMF	
1.7	Concepts of self-inductance, mutual inductance and coefficient of coupling	1
1.8	Simple Numerical Problems	1
<b>MODULE II</b>		
2.1	Single Phase system: Generation of sinusoidal voltage	1
2.2	Series Circuits: Common signals and waveforms (Sine, Square, Triangle), RMS and Average value, form factor and peak factor of AC waveforms	1
2.3	Numerical Problems on topic 2.2	1
2.4	Impedance of series circuits (RL, RC and RLC circuits). Phasor diagram of series circuits	1
2.5	Real, reactive and apparent power, power factor and Power triangle	1
2.6	Numerical Problems on topic 2.4	1
2.7	Numerical Problems on topic 2.5	1
<b>MODULE III</b>		
3.1	Three Phase System: Generation of three phase voltages- advantages of three phase systems, star and delta connection, three wire and four wire systems	1
3.2	Relation between line and phase voltages, line and phase currents	1
3.3	Expressions for power in three phase circuits	1
3.4	Definition of phase sequence, balanced supply and balanced load;	1
3.5	Relationship between line and phase values of balanced star and delta connections	1
3.6	Power in balanced three phase circuits- Numerical Problems	1

<b>MODULE IV</b>		
4.1	Working features; principle of DC generator; Types and constructional features	1
4.2	EMF equation of generator, Numerical Problems	1
4.3	Working principle of DC motor; Significance of Back EMF, torque equation	1
4.4	Numerical problems.	1
4.5	Types of D.C. motors, characteristics (series and Shunt motors only)	1
4.6	Application of DC Motors	1
4.7	Necessity of a starter for DC motor	1
4.8	Principle of operation and construction of single-phase transformers (core and shell types)	1
4.9	Emf equation, losses – Simple numerical problems	1
<b>MODULE V</b>		
5.1	Three Phase Induction Motors: Concept of rotating magnetic field - Principle of operation	1
5.2	Types and constructional features; Slip and its significance	1
5.3	Applications of squirrel cage and slip ring motors	1
5.4	Necessity of a starter, star-delta starter	1
5.5	Energy storages: fundamentals of batteries - types - primary - Secondary batteries, Lead-Acid Batteries- - characteristics - advantages - disadvantages	1
5.6	Lithium-Ion Batteries - characteristics - advantages - disadvantages	1

<b>CO Assessment Questions</b>	
CO 1	<p>Find the equivalent resistance between A and B for the network shown below</p> <p style="text-align: right;">(Apply)</p>
CO 1	Compare the power consumed in star and delta circuits using the same resistances as branches.

CO 2	An Iron ring of cross-sectional area $1.1 \text{ cm}^2$ is wound with a coil of 3000 turns. Calculate the magnetizing current required to produce a flux of 0.2 mWb in the iron path if mean length of the path is 32 cm and relative permeability of iron is 2500. Neglect magnetic leakage and fringing.
CO 2	How is transformer behaving as a magnetic isolator?
CO 3	A sinusoidal voltage $V = 240 \angle 15^\circ$ of frequency 50Hz is applied to a series RL circuit consisting of $R = 10\Omega$ and $L = 0.25 \text{ H}$ . Calculate (i) rms current and its phase angle (ii) power factor (iii) average power (iv) reactive power and (v) apparent power drawn by the circuit.
CO 3	Submit a report on, case study of an AC circuit application
CO 3	Circuit De-bugging competition
CO 4	Derive the emf equation of a transformer
CO 5	Justify the necessity of starters in three phase induction motor

### Assessment Questions

CO 1	<p>Find the equivalent resistance between A and B for the network shown below</p> <p style="text-align: right;">(Apply)</p>
CO 1	Compare the power consumed in star and delta circuits using the same resistances as branches.
CO 2	An Iron ring of cross-sectional area $1.1 \text{ cm}^2$ is wound with a coil of 3000 turns. Calculate the magnetizing current required to produce a flux of $0.2 \text{ mWb}$ in the iron path if mean length of the path is 32 cm and relative permeability of iron is 2500. Neglect magnetic leakage and fringing.
CO 2	How is transformer behaving as a magnetic isolator?
CO 3	A sinusoidal voltage $V = 240 \angle 15^\circ$ of frequency 50Hz is applied to a series RL circuit consisting of $R = 10\Omega$ and $L = 0.25 \text{ H}$ . Calculate (i) rms current and its phase angle (ii) power factor (iii) average power (iv) reactive power and (v) apparent power drawn by the circuit.
CO 3	Submit a report on, case study of an AC circuit application
CO 3	Circuit De-bugging competition
CO 4	Derive the emf equation of a transformer
CO 5	Justify the necessity of starters in three phase induction motor

<b>24ESP107</b>	<b>TECHNICAL ENGLISH FOR ENGINEERS</b>	<b>L</b>	<b>T</b>	<b>P</b>	<b>J</b>	<b>S</b>	<b>C</b>	<b>Year of Introduction</b>
		<b>2</b>	<b>0</b>	<b>2</b>	<b>0</b>	<b>4</b>	<b>3</b>	<b>2024</b>

**Preamble:** This course enables the students to use the basic skills of communication such as reading, listening, writing and speaking. The topics like Use of Language in communication, Oral Presentation, Interview Skills, Formal Writing, Reading Comprehension and Listening skills are covered in this course. The course helps the learners to communicate with group, face interviews and prepare technical documents in an effective manner.

**Prerequisite: NIL**

**Course Outcomes:** After the completion of the course the student will be able to

<b>CO 1</b>	Use vocabulary and language skills in professional communication. [Apply level]
<b>CO 2</b>	Demonstrate technical presentation and speaking skills. [Apply level]
<b>CO 3</b>	Make use of the interview skills in real life situation. [Apply level]
<b>CO 4</b>	Create professional and technical documents precisely. [Apply level]
<b>CO 5</b>	Use reading and listening techniques in an effective way. [Apply level]

**CO - PO MAPPING**

<b>CO</b>	<b>PO1</b>	<b>PO2</b>	<b>PO3</b>	<b>PO4</b>	<b>PO5</b>	<b>PO6</b>	<b>PO7</b>	<b>PO8</b>	<b>PO9</b>	<b>PO10</b>	<b>PO11</b>	<b>PO12</b>
<b>CO 1</b>								✓	✓	✓		✓
<b>CO 2</b>								✓	✓	✓		✓
<b>CO 3</b>								✓	✓	✓		✓
<b>CO 4</b>								✓		✓		✓
<b>CO 5</b>								✓	✓	✓		✓

**Assessment Pattern for Theory component**

<b>Bloom's Category</b>	<b>Continuous Assessment Tools</b>			<b>End Semester Examination</b>
	<b>Test 1</b>	<b>Test 2</b>	<b>Other tools</b>	
Remember	-	✓	✓	✓
Understand	-	✓	✓	✓
Apply	-	✓	✓	✓
Analyse			✓	
Evaluate			✓	
Create			✓	

**Assessment Pattern for Lab component**

<b>Bloom's Category</b>	<b>Continuous Assessment Tools</b>	
	<b>Class work</b>	<b>Test1</b>
Remember		
Understand	✓	✓
Apply	✓	✓
Analyse	✓	✓
Evaluate		
Create		

<b>Mark Distribution of CIA</b>							
<b>Course Structure [L-T-P-J]</b>	<b>Attendance</b>	<b>Theory [L- T]</b>			<b>Practical [P]</b>		<b>Total Marks</b>
		<b>Assignment</b>	<b>Test-1</b>	<b>Test-2</b>	<b>Class work</b>	<b>Lab Exam/ Practice</b>	
<b>2-0-2-0</b>	5	15	-	10	20	10	<b>60</b>
<b>Total Marks distribution</b>							
<b>Total Marks</b>	<b>CIA (Marks)</b>	<b>ESE (Marks)</b>			<b>ESE Duration</b>		
<b>100</b>	<b>60</b>	<b>40</b>			<b>2.5 Hours</b>		
<b>End Semester Examination [ESE]: Pattern</b>							
<b>PATTERN</b>	<b>PART A</b>	<b>PART B</b>				<b>ESE Marks</b>	
<b>PATTERN 2</b>		2 questions will be given from each module, out of which 1 question should be answered. Each question can have a maximum of 2 sub divisions. Each question carries 8 marks. Marks: (5x 8 = 40 marks) Time: 2.5 hours				40	
	Total Marks: 0	Total Marks: [5x8 = 40 marks]					

<b>SYLLABUS</b>
<b>MODULE I: Use of Language in communication</b>
Significance of Technical communication- Technical vocabulary used in formal letters, emails, reports, misspelled words, synonyms, antonyms, and paraphrasing. Grammar- Subject-verb agreement, reported speech, active-passive voice, use of adjectives and adverbs, prepositions.
<b>MODULE II: Oral Presentation</b>
Voice Modulation, tone, Intonation, pronunciation, presentation skills, public speaking skills, Types of presentations, the use of visuals in presentation, debate, G.D., brainstorming, body language, and audience analysis.
<b>MODULE III: Interview Skills</b>
Interview skills: Objectives and types of interviews, preparing for interview, interview etiquette, dress code, body language, online interview, panel interview, one-to-one interview, FAQ'S related to job interviews, and answering strategies.
<b>MODULE IV: Formal Writing</b>
Formal Writing: Letter- Formal, informal, and semi-formal. Email, Job application letters, C.V., Resume, and Biodata, minutes preparation, different types of reports, common errors in writing, use of sequence words, and Statement of purpose. Reference styling, IEEE format, bibliography, analytical and issue-based essay



writing, plagiarism.

### **MODULE V: Reading Comprehension and Listening skills**

Reading, comprehension, and summarizing: Reading Styles, speed reading, critical reading, reading and comprehending longer and shorter technical articles from journals and newspapers, SQ3R method, PQRS method, identifying transitions of text, note taking.

Listening skills: Active and Passive listening, listening for general content, listening for specific information, developing effective listening skills, barriers to effective listening, listening to longer technical talks and classroom lectures, TED talks, taking notes while listening.

#### **Text books / Reference books**

1. Meenakshi Raman and Sangeetha Sharma, Technical Communication: Principles and Practice, 3<sup>rd</sup> edition, Oxford University Press, 2015
2. Anderson, P.V, Technical Communication, Thomas Wadsworth, Sixth edition, New Delhi, 2007
3. English for Engineers and Technologists (Combined edition, Vol,1 and 2), Orient Blackswann 2010
4. Seely, John, The Oxford Guide to Writing and Speaking, Oxford university Press, 1997
5. Ganguly, Anand, Success in Interview, RPH, Fifth edition, 2006
6. Effective Communication Skills. Kul Bhushan Kumar, Khanna Book Publishing, 2022.
7. Practical English Usage. Michael Swan. OUP. 1995.
8. Remedial English Grammar. F.T. Wood. Macmillan.2007
9. On Writing Well. William Zinsser. Harper Resource Book. 2001
10. Study Writing. Liz Hamp-Lyons and Ben Heasley. Cambridge University Press. 2006.
11. Communication Skills. Sanjay Kumar and Pushplata. Oxford University Press. 2011.
12. Exercises in Spoken English. Parts. I-III. CIEFL, Hyderabad. Oxford University Press.

#### **NPTEL/SWAYAM Courses for reference:**

1. English Language for Competitive Exams Prof. Aysha Iqbal IIT Madras
2. Technical English for Engineers Prof. Aysha Iqbal IITM

### **COURSE CONTENTS AND LECTURE SCHEDULE**

No.		No. of Hours [35]
<b>MODULE 1</b>		<b>8 Hrs</b>
1.1	Introduction, misspelled words	1
1.2	Synonyms and antonyms	1
1.3	Technical vocabulary in email and letters and reports	1
1.4	Paraphrasing	1
1.5	Subject-verb agreement	1
1.6	Reported Speech	1

1.7	Active and passive voice	1
1.8	Preposition, use of adjectives and adverbs	1
<b>MODULE II</b>		<b>6 Hrs</b>
2.1	Presentation skills	1
2.2	Importance of voice modulation, tone, intonation	1
2.3	Use of visuals in presentation, public speaking skills	1
2.4	Debate and G.D – differences.	1
2.5	Body Language and audience analysis	1
2.6	Brainstorming	1
<b>MODULE III</b>		<b>6 Hrs</b>
3.1	Objectives of Interview, types of Interviews	1
3.2	Preparation strategies for attending interview	1
3.3	Dress code and body language for interviews.	1
3.4	Interview Etiquettes	1
3.5	FAQs related to job interviews	1
3.6	Strategies for different types of interviews- Online interview, panel interview, one-to-one interview.	1
<b>MODULE IV</b>		<b>9 Hrs</b>
4.1	Formal, informal, and semi-formal letters	1
4.2	Email Writing and etiquette	1
4.3	Application letter, email.	1
4.4	C.V, Resume, Biodata – introduction and differences	1
4.5	C.V, Resume, Biodata writing process	1
4.6	Minutes preparation	1
4.7	Types of reports, use of sequence words	1
4.8	Statement of purpose, referencing style, bibliography.	1
4.9	IEEE format, plagiarism, issue-based essay writing.	1
<b>MODULE V</b>		<b>6 Hrs</b>
5.1	Reading Styles	1
5.2	Speed reading, critical reading	1
5.3	Comprehending longer and shorter technical articles from journals and newspaper	1
5.4	Reading methods, SQ3R and PQRS methods, identifying transitions in text	1
5.5	Active and Passive listening, Listening for general and specific content	1
5.6	Barriers to effective listening.	1

### LESSON PLAN FOR LAB COMPONENT

No.	Topic	No. of Hours	Experiment
1	Difference between literary and technical writing style	1	Writing exercises for both creative and technical writing that highlight Grammatical and linguistic differences between two.

2	Presentation	3	Create and present a PPT based on a given topic.
3	Group Discussion	2	Group discussion and debate based on a given topic.
4	Voice modulation, tone, and intonation	1	Analyze a given video presentations of speakers, technocrats, and management experts based on the concepts learned.
5	Effects of body language in presentation and public speaking.		
6	Interview Skills	1	Mock Panel Interview
7	Interview body language and etiquette	1	Analyze the given videos of both mock/ original job interviews based on the concepts learned.
8	Report writing	1	Writing exercises for different types of reports.
10	Comprehension exercise	2	Comprehend articles from scientific journals.
			Comprehend articles from newspapers.
11	Listening exercise – 1	1	Answering the Question / Note Making from TED talks.
12	Listening exercise – 2	1	Write the subtitles and lyrics from the English movie clips and songs provided

### CO Assessment Questions

CO1	<ol style="list-style-type: none"> <li>Find the word with the correct spelling from the following list a) Accommodate b) Acommodate c) Accomadate d) Acomodate</li> <li>Which word in the following list is closest to the meaning of the word 'gloomy' a) Happy b) Sad c) Enthralled d) elated.</li> <li>Select the most suitable preposition for the sentence from the following list I was born _____ May (in / on / at) My friend lives _____ Beach Road (in/on/at)</li> </ol>
CO2	<ol style="list-style-type: none"> <li>What is the significance of body language in presentation?</li> <li>Explain the strategies to improve your Debate skills.</li> <li>How important is visual aid for presentations?</li> <li>As a student who presented a slide presentation, how will you respond to a disturbed audience?</li> </ol>
CO3	<ol style="list-style-type: none"> <li>Explain the significance of non- verbal communication in interviews.</li> <li>What are the differences that you will make while attending an online interview instead of an off line interview.</li> <li>How will you politely respond to a question asked to you in an interview to which you don't know the answer?</li> <li>As a viewer of the mock interview conducted in the class, what were the do's and don'ts to be followed in an interview.</li> </ol>

CO4	<ol style="list-style-type: none"><li>1. What are the differences between a C.V., Resume and Biodata?</li><li>2. Write an email to the manager of ABC Technologies asking for an opportunity to be included in their internship program</li><li>3. What are the different types of reports?</li></ol>
C05	<ol style="list-style-type: none"><li>1. What is critical reading? What are the advantages of critical reading over speed reading?</li><li>2. Write down the lyrics of the song as you hear it.</li><li>3. Write a synopsis of the journal article that you just read.</li></ol>

24MCJ110/ 24MCJ210	IDEA LAB	L	T	P	J	S	C	Year of Introduction
		2	0	2	0	4	1	2024

**Preamble:** This course enables the learners to understand the concepts of design, development and documentation tools under various domains in engineering. The various topics covered in this course are concepts of Microcontroller Programming, PCB Designing and Prototyping, Modelling, Slicing, Cutting, Routing, and Documentation & version control Tools. This course helps the students to design and develop real life applications using multidisciplinary engineering aspects.

**Prerequisite:** NIL

**Course Outcomes:** After the completion of the course the student will be able to

<b>CO 1</b>	Develop project using appropriate Microcontroller Programming languages. [Apply level]
<b>CO 2</b>	Develop product using PCB Design and Prototyping concepts. [Apply level]
<b>CO 3</b>	Create 2D and 3D models using appropriate tools. [Apply level]
<b>CO 4</b>	Create electronic documentation for the system/project using appropriate tools. [Apply level]
<b>CO 5</b>	Build useful and standalone system/ project with enclosures. [Apply level]

#### CO - PO MAPPING

CO	PO1	PO2	PO3	PO4	PO5	PO6	PO7	PO8	PO9	PO10	PO 11	PO 12
<b>CO 1</b>	✓	✓	✓	✓	✓	✓		✓	✓			✓
<b>CO 2</b>	✓	✓	✓	✓	✓	✓		✓	✓			✓
<b>CO 3</b>	✓	✓	✓	✓	✓	✓		✓	✓			✓
<b>CO 4</b>	✓	✓	✓	✓	✓			✓	✓	✓		✓
<b>CO 5</b>	✓	✓	✓	✓	✓	✓		✓	✓			✓

#### Assessment Pattern for Lab component

Bloom's Category	Continuous Assessment Tools	
	Class work	Test1
Remember		
Understand	✓	✓
Apply	✓	✓
Analyse	✓	✓
Evaluate	✓	
Create	✓	

#### Assessment Pattern for Project component

Bloom's Category	Continuous Assessment Tools		
	Evaluation 1	Evaluation 2	Report
Remember			
Understand	✓	✓	
Apply	✓	✓	
Analyse	✓	✓	
Evaluate		✓	
Create		✓	

<b>Mark Distribution of CIA</b>						
Course Structure [L-T-P-J]	Attendance	Theory [L- T]		Practical [P]		<b>Total</b>
		<b>Assignment</b>	<b>Test-1</b>	<b>Lab work</b>	<b>Test 2</b>	
2-0-2-0	5	10	20	*45	20	<b>100</b>

\* As part of their lab work, students are required to submit a Micro project. The total marks for the lab component in the idea lab are calculated as a cumulative sum of the continuous assessment of lab work, which carries 20 marks, and the micro project evaluation, which carries 25 marks. The micro project evaluation is further divided into three components: 10 marks for the intermediate evaluation of the micro project, 10 marks for the project presentation and demonstration, and 5 marks for the micro project report submitted at the end of the semester.

<b>Total Marks distribution</b>			
<b>Total Marks</b>	<b>CIA (Marks)</b>	<b>ESE (Marks)</b>	<b>ESE Duration</b>
100	100	-	-

### **SYLLABUS**

#### **MODULE I: Introduction Microcontroller Programming**

Introduction to micro controller and embedded systems, Introduction to Arduino and its IDE Concept of digital and analog ports, registers, memory, timer, counter. Embedded C programming: Arduino data types, operators, Array, Loop, Functions.

#### **MODULE II: Microcontroller Programming**

Embedded C programming: Working with Serial Monitor, Pins Configuration as INPUT/OUTPUT, digitalRead(), digitalWrite(), Interrupts, delay(), Pull-up resistors. Interfacing a 8-bit LCD to Arduino, Running message display. Sensor/Actuator Interface: Temperature Sensor, LDR based sensor, IR and Ultrasonic sensors, Relay, LED, Servomotor.

#### **MODULE III: PCB Designing and Prototyping**

Introduction: PCB, pads, track, SMD, through hole, via and its Design rules. Design any two simple circuit using Easy EDA/Eagle/Flat CAM, Routing and Generating GERBER file. PCB Chemical etching Vs Milling techniques, PCB Chemical Etching/Milling

#### **MODULE IV: Modelling, Slicing, Cutting, Routing**

3D modeling, Slicing, 3 D printing, 2D design using Inkscape, Laser CAD, Laser Cutting, 2D modelling, CNC Routing, CNC Routing, Tool familiarization

#### **MODULE V: Documentation and version control Tools**

Familiarization of Google Docs, Google Sheets, Google Slides, Google Drawings, Google Forms Google Sites, Creating Google sheets, Google slides, Google forms and Google sites

Doxygen – Overview, Installation, Getting started, Documenting the code, Markdown support, Lists, Grouping, Including formulas, Including tables, Graphs and diagrams, Preprocessing, Output Formats, Searching, Customizing the output, Custom Commands, Linking to external documentation,

## Reference books

1. AICTE's Prescribed Textbook: Workshop / Manufacturing Practices (with Lab Manual), Khanna Book Publishing
2. All-in-One Electronics Simplified, A.K. Maini; 2021. ISBN-13: 978-9386173393, Khanna Book Publishing Company, New Delhi.
3. Simplified Q&A - Data Science with Artificial Intelligence, Machine Learning and Deep Learning, Rajiv Chopra, ISBN: 978-9355380821, Khanna Book Publishing Company, New Delhi.
4. 3D Printing & Design, Dr. Sabrie Soloman, ISBN: 978-9386173768, Khanna Book Publishing Company, New Delhi.
5. The Big Book of Maker Skills: Tools & Techniques for Building Great Tech Projects. Chris Hackett. Weldon Owen; 2018. ISBN-13: 978-1681884325.
6. The Total Inventors Manual (Popular Science): Transform Your Idea into a Top-Selling Product. Sean Michael Ragan (Author). Weldon Owen; 2017. ISBN-13: 978-1681881584.
7. Make: Tools: How They Work and How to Use Them. Platt, Charles. Shroff/Maker Media. 2018. ISBN-13: 978-9352137374
8. The Art of Electronics. 3rd edition. Paul Horowitz and Winfield Hill. Cambridge University Press. ISBN: 9780521809269
9. Practical Electronics for Inventors. 4th edition. Paul Sherz and Simon Monk. McGraw Hill. ISBN-13: 978-1259587542
10. Encyclopedia of Electronic Components (Volume 1, 2 and 3). Charles Platt. Shroff Publishers. ISBN-13: 978-9352131945, 978-9352131952, 978-9352133703
11. Building Scientific Apparatus. 4th edition. John H. Moore, Christopher C. Davis, Michael A. Coplan and Sandra C. Greer. Cambridge University Press. ISBN-13: 978-0521878586
12. Programming Arduino: Getting Started with Sketches. 2nd edition. Simon Monk. McGraw Hill. ISBN-13: 978-1259641633
13. Make Your Own PCBs with EAGLE: From Schematic Designs to Finished Boards. Simon Monk and Duncan Amos. McGraw Hill Education. ISBN-13: 978-1260019193.
14. Pro GIT. 2nd edition. Scott Chacon and Ben Straub. A press. ISBN-13: 978-1484200773
15. Venuvinod, PK., MA. W., Rapid Prototyping – Laser Based and Other Technologies, Kluwer.
16. Ian Gibson, David W Rosen, Brent Stucker., "Additive Manufacturing Technologies: Rapid Prototyping to Direct Digital Manufacturing", Springer, 2010
17. Chapman W.A.J, "Workshop Technology", Volume I, II, III, CBS Publishers and distributors, 5<sup>th</sup> Edition, 2002

<b>COURSE CONTENTS AND LECTURE SCHEDULE</b>		
No.		No. of Hours [19]
<b>MODULE 1</b>		
1.1	Introduction to micro controller and embedded systems,	1
1.2	Introduction to Arduino and its IDE Concept of digital and analog ports, registers, memory, timer, counter.	1
1.3	Embedded C programming: Arduino data types, operators, Array, Loop, Functions.	1
<b>MODULE II</b>		
2.1	Embedded C programming: Working with Serial Monitor, Pins Configuration as INPUT/OUTPUT.	1
2.2	Embedded C programming: digitalWrite(), digitalRead(), Interrupts, delay(), Pull-up resistors.	1
2.3	Embedded C programming: Interfacing a 8 bit LCD to Arduino, Running message display	
2.4	Sensor/Actuator Interface: Temperature Sensor, LDR based sensor, IR and Ultrasonic sensors, Relay, LED, Servomotor Introduction: PCB, pads, track, SMD, through hole, via and its Design rules. Routing and Generating GERBER file	1
<b>MODULE III</b>		
3.1	Introduction: PCB, pads, track, SMD, through hole, via and its Design rules.	1
3.2	Routing and Generating GERBER file	1
3.3	PCB Chemical etching Vs Milling techniques, PCB Chemical Etching/Milling	1
<b>MODULE IV</b>		
4.1	3D modeling, Slicing, 3 D printing	1
4.2	2D design using Inkscape, Laser CAD	
4.3	Laser Cutting, 2D modelling, CNC Routing,	1
4.4	CNC Routing Tool familiarisation	
<b>MODULE V</b>		
5.1	Familiarization of Google Docs, Google Sheets, Google Slides,	1
5.2	Google Drawings, Google Forms Google Sites	1
5.3	Doxygen – Overview, Installation, Getting started, Documenting the code, Markdown support, Lists,	1
5.4	Doxygen - Grouping, including formulas, Including tables, Graphs and diagrams, Preprocessing	1
5.5	Doxygen – Output Formats, Searching, Customizing the output, Custom Commands, Linking to external documentation	1



### LESSON PLAN FOR LAB COMPONENT

No.	Topic	No. of Hours	Experiment
1	Introduction to micro controller and embedded systems,	3	Simple Embedded C programs: Arduino data types, operators, Array, Loop, Functions
2	Introduction to Arduino and its IDE Concept of digital and analog ports, registers, memory, timer, counter.		
3	Embedded C programming: Arduino data types, operators, Array, Loop, Functions.		
4	Serial Monitor, Pins Configuration as INPUT/OUTPUT, digitalRead(), digitalWrite(), Interrupts, delay(), Pull-up resistors.	5	Embedded C programs to working with Serial Monitor, Pins Configuration as INPUT/OUTPUT, digitalRead(), digitalWrite(), Interrupts, delay(), Pull-up resistors. Implement : Water level control system. Distance measurement and Display unit. Home Automation system.
5	Introduction: PCB, pads, track, SMD, through hole, via and its Design rules.	6	Design any two simple circuit using Easy EDA/ Eagle/ FlatCAM Routing and Generating GERBER file
6	PCB Chemical etching Vs Milling techniques	2	Experiments with PCB Chemical Etching/Milling
7	3D modeling, Slicing, 3 D printing, 2D design using Inkscape, Laser CAD, Laser Cutting, 2D modelling, CNC Routing, CNC Routing, Tool familiarization	14	Machining of 3D geometry on soft material such as soft wood or modelling wax, 3D scanning of computer mouse geometry surface. 3D printing of scanned geometry. 2D profile cutting of press fit box/casing in acrylic (3 or 6 mm thickness)/cardboard, D profile cutting on plywood /MDF (6-12 mm) for press fit designs

8	Familiarization of Google Docs, Google Sheets, Google Slides, Google Drawings, Google Forms Google Sites	2	Exercise for creating Google sheets, Google slides, Google forms and Google sites
9	Doxygen – Overview, Documenting the code, Markdown support, Lists, Grouping, Including formulas, Including tables, Graphs and diagrams, Preprocessing, Output Formats, Searching, Customizing the output, Custom Commands, Linking to external documentation.	4	Doxygen –Installation, Getting started Document the programs created for Raspberry pi and Arduino using Doxygen
	Familiarisation of Version control tools - GIT and GitHub	4	At least two programs in programming exercises must be done using GitHub

24HUL111	DESIGN THINKING	L	T	P	J	S	C	Year Of Introduction
		0	0	2	0	2	1	2024

**Preamble:** This course enables the students to understand the fundamentals of design thinking and use the basic tools, techniques & approaches. The various topics covered in this syllabus are: An Insight to Learning, Basics of design thinking, Being ingenious and fixing problems, Prototype and testing, Design thinking and customer centricity. This course helps the learners to apply design thinking approach while developing practical solutions for real world problems.

**Prerequisite:** NIL

**Course Outcomes:** After the completion of the course the student will be able to

<b>CO1</b>	Compare and classify the various learning styles and memory techniques and apply them in their engineering education.
<b>CO2</b>	Analyze emotional experience and inspect emotional expressions to better understand users while designing innovative products
<b>CO3</b>	Develop new ways of creative thinking and learn the innovation cycle of design thinking process for developing innovative products.
<b>CO4</b>	Propose solutions for real-world engineering problems by applying creative design thinking
<b>CO5</b>	Perceive individual differences and its impact on everyday decisions thereby lead and/or perform in a design team
<b>CO6</b>	Perform customer centric designing by intelligently accommodating customer requirements/challenges so as to eventually improve customer experience
<b>CO7</b>	Develop new designs for simple products using bio-mimicry to bring out new nature inspired designs
<b>CO8</b>	Solve practical engineering problem through innovative product design and creative solution

**CO - PO MAPPING**

CO	PO1	PO2	PO3	PO4	PO5	PO6	PO7	PO8	PO9	PO10	PO11	PO12
CO1	✓							✓	✓			✓
CO2				✓		✓		✓	✓	✓		✓
CO3	✓	✓	✓	✓		✓		✓	✓	✓		✓
CO4								✓	✓	✓		✓
CO5						✓		✓	✓	✓		✓
CO6	✓	✓	✓			✓		✓	✓	✓		✓
CO7	✓	✓	✓	✓		✓		✓	✓	✓		✓

**Assessment Pattern**

Bloom's Category	Continuous Assessment Tools	
	Class work	Test 1
Remember		
Understand	✓	✓
Apply	✓	✓
Analyse	✓	✓
Evaluate	✓	
Create	✓	

<b>Mark Distribution of CIA</b>				
<b>Course Structure [L-T-P-J]</b>	<b>Attendance</b>	<b>Class work</b>	<b>Lab Exam/ Presentation</b>	<b>Total Marks</b>
<b>0-0-2-0</b>	5	35	10	<b>50</b>
<b>Total Mark distribution</b>				
<b>Total Marks</b>	<b>CIA (Marks)</b>	<b>ESE (Marks)</b>	<b>ESE Duration</b>	
50	50	-	-	
<b>SYLLABUS</b>				
<p><b>An Insight to Learning</b> - Understanding the Learning Process, Kolb's Learning Styles, Assessing and Interpreting. Remembering Memory - Understanding the Memory process, Problems in retention, Memory enhancement techniques, Emotions: - Experience &amp; Expression, Understanding Emotions- Experience &amp; Expression, Assessing Empathy, Application with Peers.</p> <p><b>Basics of Design Thinking</b> - Definition of Design Thinking, Need for Design Thinking, Objective of Design Thinking, Concepts &amp; Brainstorming, Stages of Design Thinking Process (explain with examples) – Empathize, Define, Ideate, Prototype, Test Being Ingenious &amp; Fixing Problem - Understanding Creative thinking process, Understanding Problem Solving, Testing Creative, Problem Solving, Process of Product Design - Process of Engineering Product Design, Design Thinking Approach, Stages of Product Design, Examples of best product designs and functions, Assignment – Engineering Product Design</p> <p><b>Prototyping &amp; Testing</b> - What is Prototype? Why Prototype? Rapid Prototype Development process, Testing, Sample, Example, Test Group Marketing, Celebrating the Difference - Understanding Individual differences &amp; Uniqueness, Group Discussion and Activities to encourage the understanding, acceptance and appreciation of Individual differences</p> <p><b>Design Thinking &amp; Customer Centricity</b> - Practical Examples of Customer Challenges, Use of Design Thinking to Enhance Customer Experience, Parameters of Product experience, Alignment of Customer Expectations with Product Design, Feedback, Re-Design &amp; Re-Create Feedback loop, Focus on User Experience, Address “ergonomic challenges, User focused design, rapid prototyping &amp; testing, final product, Final Presentation – “Solving Practical Engineering Problem through Innovative Product Design &amp; Creative Solution”.</p>				
<b>Text books</b>				
<ol style="list-style-type: none"> <li>1. YousefHaik, Sangarappillai Sivaloganathan, Tamer M. Shahin, Engineering Design Process, Cengage Learning 2003, Third Edition, ISBN-10: 781305253285,</li> <li>2. Voland, G., Engineering by Design, Pearson India 2014, Second Edition, ISBN 9332535051</li> </ol>				
<b>Reference books</b>				
<ol style="list-style-type: none"> <li>1. Philip Kosky, Robert Balmer, William Keat, George Wise, Exploring Engineering, Fourth Edition: An Introduction to Engineering and Design, Academic Press 2015, 4th Edition, ISBN: 9780128012420.</li> <li>2. Clive L. Dym, Engineering Design: A Project-Based Introduction, John Wiley &amp; Sons, New York 2009, Fourth Edition, ISBN: 978-1-118-32458-5</li> <li>3. Nigel Cross, Design Thinking: Understanding How Designers Think and Work, Berg Publishers 2011, First Edition, ISBN: 978-1847886361</li> <li>4. Pahl, G., Beitz, W., Feldhusen, J., Grote, K.-H., Engineering Design: A Systematic Approach, Springer 2007, Third Edition, ISBN 978-1-84628-319-2</li> </ol>				

**Reference materials**

1. Design Thinking for Strategic Innovation: What They Can't Teach You at Business or Design School, <https://www.amazon.in/Design-Thinking-Strategic-Innovation-Business/dp/8126572698/>
2. Don't Make Me Think, Revisited: A Common Sense Approach to Web Usability (3rd Edition), <https://www.amazon.in/Dont-Make-Think-Revisited-Usability/dp/9332542864/>
3. Design as Art (Penguin Modern Classics) <https://www.amazon.in/Design-Art-Penguin-Modern-Classics/dp/0141035811/>
4. Hooked: How to Build Habit-Forming Products ₹ 368 <https://www.amazon.in/Hooked-How-Build-Habit-Forming-Products/dp/0241184835/>
5. Emotional Design <https://www.amazon.in/Emotional-Design-Don-Norman/dp/0465051367/>
6. Value Proposition Design: How to Create Products and Services Customers Want <https://www.amazon.in/Value-Proposition-Design-Products-Customers/dp/8126553073/>
7. The Art Of Creative Thinking , <https://www.amazon.in/Art-Creative-Thinking-Rod-Judkins/dp/1444794485/>
8. Lateral Thinking: A Textbook of Creativity, <https://www.amazon.in/Lateral-Thinking-Creativity-Edward-Bono/dp/0241257549/>
9. This is Service Design Thinking: Basics, Tools, Cases , <https://www.amazon.in/This-Service-Design-Thinking-Basics/dp/1118156307/>
10. The Design of Business, <https://www.amazon.in/Design-Business-Roger-L-Martin/dp/1422177807/>
11. The Design Thinking Playbook: Mindful Digital Transformation of Teams, Products, Services, Businesses, and Ecosystems <https://www.amazon.in/Design-Thinking-Playbook-Transformation-Businesses/dp/1119467470/>
12. Thinking, Fast and Slow (Penguin Press Non-Fiction) <https://www.amazon.in/Thinking-Fast-Penguin-Press-Non-Fiction/dp/0141033576/>

**LIST OF EXPERIMENTS**

<b>No.</b>	<b>Experiments</b>
1	<p>Topic: An Insight to Learning, Remembering Memory, Emotions: Experience &amp; Expression.</p> <ol style="list-style-type: none"> <li>1. Group discussion/ Video presentation that addresses the concepts that shall be conveyed through the following questions.               <ol style="list-style-type: none"> <li>a) How learning happens?</li> <li>b) What are the main components of Kolb’s cycle of experiential learning and examples?</li> <li>c) What is the memory process?</li> <li>d) What are the different memory enhancement techniques?</li> <li>e) What is the need for understanding emotions?</li> <li>f) Identify the different ways of assessing empathy and applying them among peers.</li> <li>g) Assume you got a chance to teach capitals of different countries in a UKG class. Illustrate what different memory enhancement techniques you will use through a role play.</li> </ol> </li> </ol>

	<p>2. Each team member of the group lists your positive and negative emotions. Among team members, discuss how each one of you manage each emotions. (Like finding happiness, escaping from sadness, managing anger, Facing fear, Overcoming shame etc you can put more questions). After the discussion did you get some technique to manage your emotion in a better way?</p>
2	<p>Topic: - An Approach to Introduce and Instill Design Thinking. – Class discussion based on the following questions and write down the conclusion in Work Book.</p> <ol style="list-style-type: none"> <li>What do you mean by designing something? What is design thinking and why it is needed?</li> <li>What are the different stages of design thinking process?</li> <li>How does the design thinking approach help engineers in creating innovative and efficient designs?</li> <li>How can the engineers arrive at better designs utilizing the iterative design thinking process (in which knowledge acquired in the later stages can be applied back to the earlier stages)?</li> <li>Describe the design thinking process using appropriate examples.</li> </ol>
3	<p>Topic: - Activities on becoming Ingenious to Apply Design Thinking to Solve Real-world Problems. Take up a real-world problem and apply creative thinking design to solve them. Make a video presentation based on your work that shall include the answer to following questions.</p> <ol style="list-style-type: none"> <li>What is creative thinking process?</li> <li>How can you describe the process of problem solving with examples?</li> <li>How creative thinking process helps in problem solving?</li> <li>How to test the efficacy of creative problem solving process?</li> </ol>
4	<p>Topic :- Perform Designing of an Innovative Product-</p> <ol style="list-style-type: none"> <li>Perform group discussion on following points <ol style="list-style-type: none"> <li>How is engineering product design different from other kinds of design?</li> <li>Where and when do engineers perform product design?</li> <li>What are the different stages of product design?</li> <li>What are the different examples for best product designs and functions?</li> </ol> </li> <li>Based on the concepts learned, design an innovative product in your mind and give presentation.</li> </ol>
5	<p>Topic: - Learn the Prototype Development Process and Testing. Illustrate the following concepts using appropriate tools.</p> <ol style="list-style-type: none"> <li>How to predict whether the design will function well or not?</li> <li>How do mathematics and physics become a part of the design process?</li> <li>What is Prototype? Why it is needed?</li> <li>What is rapid prototype development process?</li> <li>List the different methods in which the prototype of a product can be generated and tested.</li> </ol>
6	<p>Topic- Active Learning the Process of Divergent-Convergent Thinking and Designing in a Team:</p>

	<p>1. Perform group discussion and/or other activities within a design team to refine and narrow down to the 'best design'. Create a report which specifies, how you identified and managed the following questions during the design.</p> <ol style="list-style-type: none"> <li>a) Describe how to create a number of possible designs and then how to refine and narrow down to the 'best design'?</li> <li>b) Why differences and uniqueness of individuals arise while designing in a team?</li> <li>c) How to manage conflicts in a design team?</li> <li>d) What is the need for different ways for communicating any design such as graphical, oral, written, presentation, models, prototypes, and so on?</li> </ol>
7	<p>Topic: - End User Feedback to Improve Design</p> <p>Synthesize End User Feedback to Improve Design Solution you identified in the exercise number 6.</p>
8	<p>Topic: - Develop Nature-inspired Designs utilizing Bio-mimicry, aesthetic , ergonomic and life cycle design approach:</p> <ol style="list-style-type: none"> <li>i) Class discussion to understand the following concepts <ol style="list-style-type: none"> <li>a) What is the significance of Modular Design, Life Cycle Design Approaches in Design?</li> <li>b) How does the intelligence in nature inspire engineering designs? Give examples</li> <li>c) How do aesthetic and ergonomic challenges modify designs?</li> <li>d) How do concepts like value engineering, concurrent engineering and reverse engineering influence engineering designs?</li> </ol> </li> <li>ii) Based on the understanding you acquired through discussion develop new designs for simple products using bio-mimicry so as to bring out new nature inspired designs.</li> </ol>
9	<p>Topic: - Use Feedback to Improve Designs through Re-Design and Re-create. Get feedback of your any one of the earlier design exercises from the rest of the student groups and redesign accordingly. Also</p> <ol style="list-style-type: none"> <li>i) Answer the following questions <ol style="list-style-type: none"> <li>a) How feedbacks can improve designs? How user experience helps the re-design?</li> <li>b) What is a typical feedback loop in design process?</li> <li>c) What is user focused design?</li> <li>d) What is the role of rapid prototyping &amp; testing in developing the final design of products?</li> </ol> </li> <li>ii) Make a presentation to show the process of redesigning of an existing product based on feedbacks.</li> </ol>
10	<p>Topic: - Applications of Design Thinking</p> <p>Make presentation to illustrate that it is possible to provide innovative solutions for practical problems through Design Thinking</p>

24BST120	BIOLOGY FOR ENGINEERS						L	T	P	J	S	C	Year of Introduction
							2	0	0	0	2	2	2024
<p><b>Preamble:</b> This course provides students with a comprehensive understanding of biological systems from an engineering perspective, covering topics such as Cell Structure, Neuron function, human organ systems, and Bio Design principles. Through this exploration, students acquire the knowledge and skills needed to engage in bioengineering applications, enabling them to develop advanced technologies for societal improvement. The course also cultivates an interest in interdisciplinary research, promoting the integration of biology and engineering disciplines.</p>													
<p><b>Prerequisite:</b> Nil</p>													
<p><b>Course Outcomes:</b> After the completion of the course the student will be able to</p>													
<b>CO 1</b>	Identify the origin of bio signals and their relevance in biological systems. (Understand level)												
<b>CO 2</b>	Compare Brain as a CPU System, Eye as a Camera system and Heart as a pump system. (Understand level)												
<b>CO 3</b>	Compare Lungs as purification system, Kidney as a filtration system, and Musculoskeletal System as support system. (Understand level)												
<b>CO 4</b>	Demonstrate the mechanism of Nature-Bioinspired Materials. (Understand level)												
<b>CO 5</b>	Explain Bio-printing, 3D Printing, and Bioengineering: From Tissues and Foods to Diagnostics and Environmental solutions (Understand level)												
<b>CO - PO MAPPING</b>													
CO	P01	P02	P03	P04	P05	P06	P07	P08	P09	P010	P011	P012	
<b>CO 1</b>	✓												
<b>CO 2</b>	✓									✓			
<b>CO 3</b>	✓									✓			
<b>CO 4</b>	✓						✓		✓	✓			
<b>CO 5</b>	✓								✓	✓		✓	



<b>Assessment Pattern</b>					
<b>Bloom's Category</b>	<b>Continuous Assessment Tools</b>			<b>End Semester Examination</b>	
	<b>Test1</b>	<b>Test 2</b>	<b>Other tools</b>		
Remember	✓	✓	✓		
Understand	✓	✓	✓		
Apply		✓			
Analyse					
Evaluate					
Create					
<b>Mark Distribution of CIA</b>					
<b>Course Structure [L-T-P-J]</b>	<b>Attendance</b>	<b>Theory [L- T]</b>			<b>Total Marks</b>
		<b>Assignment</b>	<b>Test-1</b>	<b>Test-2</b>	
2-0-0-0	5	35	30	30	100
<b>Total Mark Distribution</b>					
<b>Total Marks</b>	<b>CIA (Marks)</b>	<b>ESE (Marks)</b>		<b>ESE Duration</b>	
100	100	-		-	
<b>SYLLABUS</b>					
<b>MODULE I: Introduction to bio engineering and cell structure (5 hours)</b>					
Need to study Biology: – Life Science Studies Significance – Bio Inspired Inventions – Role of Biology in Next Generation Technology Development – Cell Structure – Cell Potential – Action Potential – introduction to Bio signals– Sodium Potassium channels – Neuron function					
<b>MODULE II: Human Organ Systems and Bio Design -1 (6 hours)</b>					
Brain as a CPU system (Structure, CNS and Peripheral Nervous System, signal transmission, EEG-application for prosthetic control and neurological disease diagnosis and prognosis).					

Eye as a Camera system (Structure of rod and cone cells, optical corrections, cataract, lens materials, bionic eye).

Heart as a pump system (Structure, electrical signaling – ECG monitoring and heart related issues, reasons for blockages of blood vessels, design of stents, pacemakers, defibrillators)

### **MODULE III: Human Organ Systems and Bio Design -2 (5 hours)**

Lungs as purification system (Structure, gas exchange mechanisms, spirometry, abnormal lung physiology - Chronic Obstructive Pulmonary Disease (COPD), Ventilators, Heart-lung machine).

Kidney as a filtration system (Structure, mechanism of filtration, Chronic Kidney Disease (CKD), Dialysis systems).

Musculoskeletal System (Structure, mechanisms, EMG, Engineering solutions to musculoskeletal disorders- assistive devices, exoskeletons).

### **MODULE IV: Nature-Bioinspired Materials and Mechanism (4 hours)**

Echolocation (ultrasonography, sonars), Photosynthesis (photovoltaic cells, bionic leaf). Bird flying (GPS and aircrafts), Lotus leaf effect (Super hydrophobic and self-cleaning surfaces), Genetics: Concepts of recessiveness and dominance. Concept of mapping of phenotype to genes.

### **MODULE V: Trends in Bioengineering (4 hours)**

Bioprinting techniques and materials, 3D printing of ear, bone and skin. 3D printed foods. Electronic tongue and electronic nose in food science, DNA origami and Biocomputing, Introduction to bioinformatics and its applications, Bioimaging and Artificial Intelligence for disease diagnosis.

#### **Text books**

1. Human Physiology, Stuart Fox, Krista Rompolski, McGraw-Hill eBook. 16th Edition, 2022
2. Biology for Engineers, Thyagarajan S., Selvamurugan N., Rajesh M.P., Nazeer R.A., Thilagaraj W., Barathi S., and Jaganthan M.K., Tata McGraw-Hill, New Delhi, 2012.

#### **Reference books**

1. Biology for Engineers, Arthur T. Johnson, CRC Press, Taylor and Francis, 2011
2. Biomedical Instrumentation, Leslie Cromwell, Prentice Hall 2011.
3. Biology for Engineers, Sohini Singh and Tanu Allen, Vayu Education of India, New Delhi, 2014.
4. Biomimetics: Nature-Based Innovation, Yoseph Bar-Cohen, 1st edition, 2012, CRC Press.

5. Bio-Inspired Artificial Intelligence: Theories, Methods and Technologies, D. Floreano and C. Mattiussi, MIT Press, 2008.
6. Bioremediation of heavy metals: bacterial participation, by C R Sunilkumar, N Geetha A C Udayashankar Lambert Academic Publishing, 2019.
7. 3D Bioprinting: Fundamentals, Principles and Applications by Ibrahim Ozbolat, Academic Press, 2016.
8. Electronic Noses and Tongues in Food Science, Maria Rodriguez Mende, Academic Press, 2016.

### **COURSE CONTENTS AND LECTURE SCHEDULE**

No.		No. of Hours
<b>MODULE I</b>		
1.1	Need to study Biology: – Life Science Studies Significance	1
1.2	Bio Inspired Inventions – Role of Biology in Next Generation Technology Development	1
1.3	Cell Structure – Cell Potential – Action Potential	1
1.4	Introduction to Bio signals	1
1.5	Sodium Potassium channels – Neuron function	1
<b>MODULE II</b>		
2.1	Brain as a CPU system (Structure, Nervous System, signal transmission)	1
2.2	Brain as a CPU system (EEG, prosthetic control and neurological disease diagnosis)	1
2.3	Eye as a Camera system (architecture of rod and cone cells, optical corrections)	1
2.4	Eye as a Camera system (cataract, lens materials, bionic eye).	1
2.5	Heart as a pump system (Structure, electrical signaling)	1
2.6	Heart as a pump system (ECG monitoring and heart related issues)	1
<b>MODULE III</b>		
3.1	Lungs as purification system (Structure, gas exchange mechanisms, spirometry).	1
3.2	Lungs as purification system (abnormal lung physiology – COPD, Ventilators, Heart-lung machine).	1
3.3	Kidney as a filtration system (Structure, mechanism of filtration, CKD, Dialysis systems).	1

3.4	Musculoskeletal System (Structure, mechanisms)	1
3.5	Musculoskeletal System (EMG, Engineering solutions to musculoskeletal disorders- assistive devices, exoskeletons)	1
<b>MODULE IV</b>		
4.1	Echolocation (ultrasonography, sonars), Photosynthesis (photovoltaic cells, bionic leaf).	1
4.2	Bird flying (GPS and aircrafts), Lotus leaf effect (Super hydrophobic and self-cleaning surfaces)	1
4.3	Genetics: Concepts of recessiveness and dominance. Concept of mapping of phenotype to genes.	1
4.4	Genetics: Concept of segregation and independent assortment.	1
<b>MODULE V</b>		
5.1	Bioprinting techniques and materials, 3D printing of ear, bone and skin.	1
5.2	3D printed foods. Electronic tongue and electronic nose in food science,	1
5.3	DNA origami and Biocomputing	1
5.4	Introduction to bioinformatics and its applications. Bioimaging and Artificial Intelligence for disease diagnosis.	1

<b>CO Assessment Questions</b>	
1	Identify the role of biology in the development of next-generation technologies and demonstrate key areas where biological principles are applied.
2	Make a presentation on the analogy of Human Brain with CPU
3	Demonstrate through creating a model of lungs as a purification system.
4	Group discussion activity: Discussion on different bio-inspired material for electronic tongue
5	Submit a report on the application of bio-imaging and AI in medical diagnosis

24ESP121	ELECTRONIC DESIGN AND SIMULATION						L	T	P	J	S	C	Year of Introduction
							1	0	2	0	3	2	2024
<p><b>Preamble:</b> This course gives a basic introduction to electronic components, circuits and simulation platforms. It is essential for keeping the learners aligned in the electronic stream from the very beginning and will be helpful in understanding core subjects with a practical mind set and help to simulate their theoretical understandings. The course inculcates a skill of learning by doing.</p>													
<b>Prerequisite:</b> NIL													
<b>Course Outcomes:</b> After the completion of the course the student will be able to													
<b>CO 1</b>	Identify and test various electronic components. (Understand Level)												
<b>CO 2</b>	Simulate simple circuits using LT Spice. (Understand Level)												
<b>CO 3</b>	Design first order RC circuits. (Understand Level)												
<b>CO 4</b>	Perform testing of simple electronic circuits.(Apply Level)												
<b>CO - PO MAPPING</b>													
<b>CO</b>	<b>PO1</b>	<b>PO2</b>	<b>PO3</b>	<b>PO4</b>	<b>PO5</b>	<b>PO6</b>	<b>PO7</b>	<b>PO8</b>	<b>PO9</b>	<b>PO10</b>	<b>PO11</b>	<b>PO12</b>	
<b>CO 1</b>	✓												
<b>CO 2</b>	✓				✓							✓	
<b>CO 3</b>	✓	✓											
<b>CO 4</b>	✓	✓			✓							✓	
<b>Assessment Pattern for Theory component</b>													
<b>Bloom's Category</b>	<b>Continuous Assessment Tools</b>			<b>End Semester Examination</b>									
	<b>Test1</b>	<b>Test 2</b>	<b>Other tools</b>										
Remember	✓		✓										
Understand	✓		✓										
Apply	✓		✓										
Analyse													
Evaluate													
Create													

<b>Assessment Pattern for Lab component</b>							
<b>Bloom's Category</b>		<b>Continuous Assessment Tools</b>					
		<b>Class work</b>			<b>Test1</b>		
Remember		✓			✓		
Understand		✓			✓		
Apply		✓			✓		
Analyse							
Evaluate							
Create							
<b>Mark Distribution of CIA</b>							
<b>Course Structure [L-T-P-J]</b>	<b>Attendance</b>	<b>Theory [L- T]</b>			<b>Practical [P]</b>		<b>Total Marks</b>
		<b>Assignment</b>	<b>Test-1</b>	<b>Test-2</b>	<b>Class work</b>	<b>Lab Exam</b>	
<b>1-0-2-0</b>	5	10	20	-	25	40	<b>100</b>
<b>Total Marks distribution</b>							
<b>Total Marks</b>	<b>CIA (Marks)</b>	<b>ESE (Marks)</b>			<b>ESE Duration</b>		
100	100	-			-		
<b>SYLLABUS</b>							
<b>MODULE I : Electronic Components &amp; Measuring Instruments (3 hours)</b>							
Power Supply: AC, DC, Variable supply.							
Parameters of Voltage and Current: Peak, RMS, Average value.							
Measuring Instruments: Voltmeter, Ammeter, Multimeter. Block diagram of Function Generator, CRO and DSO.							
Electronic components: Resistor, Capacitor, LED, LDR, Relay.							
<b>MODULE II : Electronic Simulation (2 hours)</b>							
Simulation Environments: LT Spice, Proteus. Diode – Characteristics simulation, equivalent model. Design and Simulation of simple circuits using LED, Resistor and switch.							
<b>MODULE III : Electronic Circuits (4 hours)</b>							
Clipping and Clamping Circuits: Working and simulation. Basic DC power supply with waveforms, SMPS and its comparison with linear power supply.							

<b>MODULE IV : First order RC Circuits (3 hours)</b>		
RC Time Constant and its derivation.		
Working and Simulation: RC Integrator, Differentiator, High Pass filter, Low Pass filter and its frequency response.		
<b>MODULE V : Printed Circuit Boards (1 hour)</b>		
PCB Chemical etching and PCB milling. Soldering – De soldering.		
Project using simple components: Design, Simulation and Prototyping.		
<b>Text books</b>		
<ol style="list-style-type: none"> <li>1. N.N. Bhargava, D.C.Kulshreshtha, S. C. Gupta, Basic Electronics and Linear circuits, Mc Graw Hill Education, 2<sup>nd</sup> edition, 2017.</li> <li>2. Robert Boylestad and L Nashelsky, “Electronic Devices and Circuit Theory”, 11/e Pearson, 2015.</li> <li>3. Simon Monk , "Make Your Own PCBs with EAGLE: From Schematic Designs to Finished Boards (Electronics)".</li> </ol>		
<b>Reference books</b>		
<ol style="list-style-type: none"> <li>1. David A Bell, “Electronic Devices and Circuits”, Oxford University Press, 2008.</li> <li>2. Neamen D., “Electronic Circuits, Analysis and Design”, 3/e, TMH, 2007.</li> <li>3. Introduction to Spice simulation <a href="https://www.coursera.org/lecture/averagedswitchmodelingandsimulation/introduction-to-spice-simulations-D8mvu">https://www.coursera.org/lecture/averagedswitchmodelingandsimulation/introduction-to-spice-simulations-D8mvu</a></li> <li>4. LT Spice tutorial by ANALOG DEVICES <a href="https://www.analog.com/en/education/education-library/videos/video-series/ltspice-getting-started-tutorial.html">https://www.analog.com/en/education/education-library/videos/video-series/ltspice-getting-started-tutorial.html</a></li> </ol>		
<b>COURSE CONTENTS AND LECTURE SCHEDULE</b>		
No.		No. of Hours
<b>MODULE 1</b>		
1.1	Power Supply: AC, DC, Variable supply. Parameters of Voltage and Current: Peak, RMS, Average value.	1
1.2	Measuring Instruments: Voltmeter, Ammeter, Multimeter.	1
1.3	Function Generator, CRO and DSO - block diagrams.	1
<b>MODULE II</b>		
2.1	Simulation Environments Introduction: LT Spice, Proteus	1
2.2	Diode - Characteristics, equivalent model.	1

	Design of simple circuit using LED, Resistor, Switch.	
<b>MODULE III</b>		
3.1	Clipping Circuits	1
3.2	Clamping Circuits	1
3.3	Basic DC power supply with waveforms	1
3.4	SMPS block diagram and working.	1
<b>MODULE IV</b>		
4.1	RC Time Constant and its derivation.	1
4.2	Differentiator and Integrator	1
4.3	First Order RC Low Pass filter and High Pass filter.	1
<b>MODULE V</b>		
5.1	Basic process of PCB prototyping: Chemical etching and Milling	1

### LESSON PLAN FOR LAB COMPONENT

No.	Topic	No. of Hours	Experiment
1	Component value identification and testing.	1	Expt.1: Resistor and Capacitor value identification and testing.
2	Familiarization of Multimeter.	1	Expt.2: Measure voltage, current and resistance using multimeter.
3	Familiarization of DSO.	1	Expt.3: Measure frequency, Time period, $V_{pp}$ , $V_{max}$ , $V_{DC}$ of a given signal.
4	Familiarize components: LED, LDR and Potentiometer.	1	Expt.4: Test the working of LED, LDR and potentiometer.
5	Familiarize component: Relay	1	Expt.5: Setup a switching application using electromechanical relay.
6	BJT and FET Testing	1	Expt.6: Test FET and BJT using multimeter.



7	LT Spice and Proteus Introduction	1	Expt.7: Familiarize LT spice and proteus simulation environments – components, visualizations.
8	Simulate diode characteristics	1	Expt.8: Simulate diode forward and reverse characteristics.
9	Simulate a simple basic circuit	1	Expt.9: Simulate an LED - resistor circuit and measure the current flow.
10	Simulate Clipping circuit	1	Expt.10: Simulate positive and negative clipping circuits and verify the transfer characteristics.
11	Simulate Clamping circuit	1	Expt.11: Simulate positive and negative clamping circuits.
12	Simulate DC Power supply	1	Expt.12: Simulate DC power supply and check waveforms at various nodes.
13	First order RC Circuit	1	Expt.13: Simulate RC differentiator and integrator.
14	First order RC Circuit	1	Expt.14: Simulate first order LPF and plot the frequency response.
15	First order RC Circuit	1	Expt.15: Simulate first order HPF and plot the frequency response.
16	Soldering and De-soldering	1	Expt.16: Solder the given components in general purpose PCB and de-solder them.
17	Troubleshooting Circuits	1	Expt.17: Troubleshoot the given circuit and make it working.
18	PCB Chemical etching	1	Expt.18: Perform chemical etching of PCB using FeCl solution.

19	PCB Milling	1	Expt.19: Convert a PCB layout to CNC machine file for PCB milling.
20	Project Design phase	1	Expt.20: Identify a problem and design a circuit to solve it.
21	Project Simulation	1	Expt.21: Simulate and verify the output of the designed circuit.
22	Project PCB Design	1	Expt.22: Design a PCB for your circuit.
23	Project Assembling and Testing	1	Expt.23: Assemble the components and test the prototype.

<b>CO Assessment Questions</b>	
1	Select a resistor/capacitor and identify its value and test it using a multimeter.
2	Simulate any series or shunt clipper in LT spice and verify the output.
3	Design a low pass filter and simulate the same in LT spice and verify the frequency response.
4	Troubleshoot the given faulty circuit and make it a functional circuit.

**SEMESTER-II**  
**SYLLABUS**

24MAP200	Ordinary Differential Equations and Transforms	L	T	P	J	S	C	Year of Introduction 2024
		3	1	2	0	5	5	

**Preamble:**

This course is to familiarize prospective engineers with some advanced concepts and methods in Mathematics which include ordinary differential equations, partial differential equations, and basic transforms such as Laplace and Fourier Transforms and Fourier series which are invaluable for any engineer's mathematical toolbox. The topics treated in this course have applications in all branches of engineering.

**Prerequisite:** Calculus of single and multivariable functions and partial differentiation.

**Course Outcomes:** After the completion of the course the student will be able to

<b>CO 1</b>	Solve homogeneous and non-homogeneous linear differential equations with constant coefficients (Apply level).
<b>CO 2</b>	Apply Laplace transforms to solve ordinary differential equations arising in engineering (Apply level).
<b>CO 3</b>	Develop the given functions as Fourier series expansions and apply them to solve problems arising in engineering (Apply level).
<b>CO 4</b>	Determine Fourier transforms of functions and learn their applications (Apply level).
<b>CO 5</b>	Use the concept of Z- transforms to solve practical problems (Apply level).

**CO - PO MAPPING**

CO	PO1	PO2	PO3	PO4	PO5	PO6	PO7	PO8	PO9	PO10	PO11	PO12
CO 1	✓	✓			✓			✓	✓			✓
CO 2	✓	✓			✓			✓	✓			✓
CO 3	✓	✓			✓			✓	✓			✓
CO 4	✓	✓			✓			✓	✓			✓
CO 5	✓	✓			✓			✓	✓			✓

**Assessment Pattern for Theory component**

Bloom's Category	Continuous Assessment Tools			End Semester Examination
	Test1	Test 2	Other tools	
Remember	✓	✓	✓	✓
Understand	✓	✓	✓	✓
Apply	✓	✓	✓	✓
Analyse				
Evaluate				
Create				

**Assessment Pattern for Lab component**

Bloom's Category	Continuous Assessment Tools	
	Classwork	Test1
Remember	✓	✓
Understand	✓	✓
Apply	✓	✓
Analyse		
Evaluate		
Create		

Mark Distribution of CIA							
Course Structure [L-T-P-J]	Attendance	Theory [L- T]			Practical [P]		Total Marks
		Assignment	Test-1	Test-2	Class work	Lab Exam	
3-1-2-0	5	10	12.5	12.5	10	10	60

Total Marks distribution			
Total Marks	CIA (Marks)	ESE (Marks)	ESE Duration
100	60	40	2.5 hours

End Semester Examination [ESE]: Pattern			
PATTERN	PART A	PART B	ESE Marks
PATTERN 2		2 questions will be given from each module, out of which 1 question should be answered. Each question can have a maximum of 2 sub divisions.  Each question carries 8 marks.  Marks: (5x 8 = 40 marks)  Time: 2.5 hours	40
	Total Marks: 0	Total Marks: [5x8 = 40 marks]	

### SYLLABUS

#### MODULE I : (Ordinary differential equations)

Homogenous linear differential equation of second order, superposition principle, general solution, homogenous linear ODEs with constant coefficients-general solution. Solution of Euler-Cauchy equations (second order homogeneous only). Non-homogenous linear ODEs-general solution, solution by the method of undetermined coefficients (for the right-hand side of forms  $x^n, e^{kx}, \sin ax, \cos ax, e^{ax} \sin ax, e^{ax} \cos ax$  and their linear combinations), method of variation of parameters. Solution of higher order equations-homogeneous linear ODE with constant coefficients.

#### MODULE II : (Laplace transforms)

Laplace Transform and its inverse, Existence theorem (without proof), linearity, Laplace transform of basic functions, first shifting theorem, Laplace transform of derivatives and integrals, solution of differential equations using Laplace transform, Unit step function, Second shifting theorem. Convolution theorem (without proof) and its application to finding inverse Laplace transform of products of functions.

#### MODULE III : (Fourier Series)

Taylor series (without proof, assuming the possibility of power series expansion in appropriate domains), Binomial series and series representation of exponential, trigonometric, logarithmic functions (without proofs of convergence); Fourier series, Euler formulas, Convergence of Fourier series (without proof), half range sine and cosine series, Parseval's theorem (without proof).

**MODULE IV : (Fourier Transforms)**

Fourier integral representation, Fourier sine and cosine integrals. Fourier sine and cosine transforms, inverse sine and cosine transform. Fourier transform and inverse Fourier transform, basic properties.

**MODULE V : (Z -Transforms)**

Introduction to Z-transform, definition, some standard Z-transforms - and their inverses, linearity property, damping rule, some standard results, convolution, region of convergence of two-sided Z -transforms, evolution of inverse Z- transform using partial fraction.

**Text books**

1. H. Anton, I. Biven S.Davis, "Calculus", Wiley, 10<sup>th</sup> edition, 2015.
2. Erwin Kreyszig, "Advanced Engineering Mathematics", Wiley, 10<sup>th</sup> edition, 2015.
3. B.S. Grewal, Higher Engineering Mathematics, Khanna Publishers, 44th Edition, 2018

**Reference books**

9. J. Stewart, Essential Calculus, Cengage, 2<sup>nd</sup> edition, 2017
10. G.B. Thomas and R.L. Finney, Calculus and Analytic geometry, 9<sup>th</sup> Edition, Pearson, Reprint, 2002.
11. Peter O Neil, Advanced Engineering Mathematics, 7th Edition, Thomson, 2007.
12. Louis C Barret, C Ray Wylie, "Advanced Engineering Mathematics", Tata McGraw Hill, 6<sup>th</sup> edition, 2003.
13. Veerarajan T, "Engineering Mathematics for first-year", Tata McGraw - Hill, 2008.
14. Srimanta Pal, Subodh C. Bhunia, "Engineering Mathematics", Oxford University Press, 2015.
15. Ronald N. Bracewell, "The Fourier Transform and its Applications", McGraw - Hill International Editions, 2000.
16. Prof. Haynes Miller, Prof. Arthur Mattuck, Differential Equations [MITOPENCOURSEWARE] <https://ocw.mit.edu/courses/18-03-differential-equations-spring-2010/download/> (Relevant sections)
17. Prof. Alan V. Oppenheim, Signals and Systems [MITOPENCOURSEWARE] <https://ocw.mit.edu/courses/res-6-007-signals-and-systems-spring-2011/pages/introduction/> (Relevant sections).

**COURSE CONTENTS AND LECTURE SCHEDULE**

No.		No. of Hours
<b>MODULE 1</b>		
1.1	Homogenous linear equation of second order, Superposition principle, general solution	1
1.2	Homogenous linear ODEs of second order with constant coefficients.	1
1.3	Homogenous linear ODEs of second order with constant coefficients (continued).	1
1.4	Second order Euler-Cauchy equation	1
1.5	Non-homogenous linear differential equations of second order with constant coefficient-solution by undetermined coefficients.	1

1.6	Non-homogenous linear differential equations of second order with constant coefficient-solution by undetermined coefficients	1
1.7	Variation of parameters	1
1.8	Higher-order equations with constant coefficients	1
1.9	Higher-order equations with constant coefficients	1
<b>MODULE II</b>		
2.1	Laplace Transform, Inverse Transform, Linearity	1
2.2	First shifting theorem, transform of basic functions	1
2.3	Transform of derivatives and integrals	1
2.4	Solution of Differential equations, Initial value problems by Laplace transform method.	1
2.5	Solution of Differential equations, Initial value problems by Laplace transform method. (Continued)	1
2.6	Unit step function -Second shifting theorem	1
2.7	Unit step function -Second shifting theorem (Continued)	1
2.8	Convolution and related problems.	1
2.9	Convolution and related problems (Continued).	1
<b>MODULE III</b>		
3.1	Taylor series, Binomial series.	1
3.2	Taylor series, Binomial series (continued)	1
3.3	Series representation of exponential, trigonometric, and logarithmic functions	1
3.4	Fourier series, Euler formulas	1
3.5	Fourier series, Euler formulas (Continued)	1
3.6	Convergence of Fourier series (Dirichlet's conditions).	1
3.7	Half-range sine and cosine series	1
3.8	Half-range sine and cosine series (Continued)	1
3.9	Parseval's theorem.	1
<b>MODULE IV</b>		
4.1	Fourier integral representation	1
4.2	Fourier integral representation (Continued)	1
4.3	Fourier Cosine and Sine integrals	1
4.4	Fourier Cosine and Sine integrals (Continued)	1
4.5	Fourier Cosine and Sine transform	1
4.6	Fourier Cosine and Sine transform (Continued)	1
4.7	Fourier transforms and its inverse transforms, basic properties.	1
4.8	Fourier transforms and its inverse transforms, basic properties (Continued)	1
<b>MODULE V</b>		
5.1	Z-transform, some standard Z-transforms - and their inverses	1
5.2	Z-transform, some standard Z-transforms - and their inverses (Continued)	1
5.3	Linearity property, damping rule	1
5.4	Linearity property, damping rule (Continued)	1

5.5	Some standard results	1
5.6	Convolution	1
5.7	Region of convergence of two-sided Z -transforms	1
5.8	Region of convergence of two-sided Z -transforms (Continued)	1
5.9	Evolution of inverse Z- transform using partial fraction	1
5.10	Evolution of inverse Z- transform using partial fraction (Continued)	1

### LESSON PLAN FOR LAB COMPONENT (Using Python Programming)

No.	Topic	No. of Hours	Experiment
1.	Basic Mathematical Operations	4	Labels, Different Kinds of Numbers, working with fractions, complex numbers, calculating factors of an integer, generating multiplication tables, finding roots of a quadratic equation
2.	Visualizing Data with Graphs	4	Understanding the cartesian coordinate planes, working with lists and tuples, creating graphs with Matplotlib, Pyplot, and adding titles and labels.
3.	Algebra, Differentiation, Integral evaluations	4	Symbols, symbolic operations, matrix operations, differentiation, and integration.
4.	Ordinary Differential Equations	4	Solutions of ordinary differential equations, solution curves.
5.	Fourier Series	2	Fourier series of functions, graphical representation of Fourier series.
6.	Integral Transforms	2	Laplace and Fourier transform of functions, Inverse transform.

### CO Assessment Questions

1	<ol style="list-style-type: none"> <li>Solve <math>y'' - y = 0</math> for the initial conditions <math>y(0) = 1, y'(0) = -1</math>. Then change the initial conditions to <math>y(0) = 1.001, y'(0) = -0.999</math> and explain why this small change of 0.001 causes a larger change later. Sketch the graph of the solution in both cases using any Mathematical software and comment.</li> <li>Find the current <math>I(t)</math> in an <math>RLC</math>-circuit with <math>R = 11\Omega</math> (ohms), <math>L = 0.1H</math> (henry), <math>C = 10^{-2} F</math> (farad), which is connected to a source of EMF <math>E(t) = 110\sin(60 \cdot 2\pi t) = 110\sin 377t</math> (hence <math>60 \text{ Hz} = 60\text{cycles/sec}</math>, the usual in the U.S. and Canada; in Europe it would be <math>220 \text{ V}</math> and <math>50 \text{ Hz}</math>). Assume that current and capacitor charge are 0 when <math>t = 0</math>.</li> <li>Solve the differential equation of <math>y''' - 3y'' + 3y' - y = e^x - x - 1</math>.</li> <li><b>Team Work:</b> A 10-kg mass is attached to a spring having a spring constant of <math>140 \text{ N/m}</math>. The mass is started in motion from the equilibrium position with an initial velocity of <math>1 \text{ m/sec}</math> in the upward</li> </ol>
---	--



	<p>direction and with an applied external force given by <math>\sin t</math> (in newtons). The mass is in a viscous medium with a coefficient of resistance equal to 90 N-sec m. Formulate an initial value problem that models the given system; solve the model and interpret the results. Also include Python code for solving ODE. Prepare a short report on the problem highlighting the observations you made and interpretation of the results.</p>
2	<ol style="list-style-type: none"> <li>Using convolution, determine the response of the damped mass-spring system modeled by <math>y'' + 3y' + 2y = r(t)</math>, <math>r(t) = 1</math> if <math>1 &lt; t &lt; 2</math> and 0 otherwise, <math>y(0) = y'(0) = 0</math>.</li> <li>Solve differential equation <math>9y'' + 6y' + y = 0</math>, <math>y(0) = 3</math>, <math>y'(0) = 1</math> using Laplace transforms. Use any mathematical software find the solution and compare the solutions.</li> <li><b>Team Work:</b> Find at least two applications of Laplace transforms in the engineering domain. Prepare a short report and a presentation of the same.</li> </ol>
3	<ol style="list-style-type: none"> <li>Use Maclaurin series of <math>\ln(1+x)</math>, <math>-1 &lt; x \leq 1</math> to find an approximate value of <math>\ln 2</math>.</li> <li>Find the Fourier series of the function <math>f(x) = x^2</math>, <math>-2 \leq x &lt; 2</math>, <math>f(x+4) = f(x)</math>. Hence using Parseval's identity prove that <math>1 + \frac{1}{2^4} + \frac{1}{3^4} + \dots = \frac{\pi^4}{90}</math>.</li> <li><b>Team Work:</b> Find the Fourier series of the function obtained by passing the voltage <math>v(t) = V_0 \cos 100\pi t</math> through a half-wave rectifier that clips the negative half-waves. <ol style="list-style-type: none"> <li>Write a program for obtaining partial sum of the Fourier series so obtained.</li> <li>Choose the first 5 or more partial sums until they approximate the given function reasonably well. Compare and comment.</li> </ol> </li> </ol>
4	<ol style="list-style-type: none"> <li>Find Fourier cosine transform and sine transform of any function. Write a short report on ways of obtaining these transforms, with illustrations by examples of your own.</li> <li>Find the Fourier integral representation of function defined by <math>f(x) = e^{-x}</math> for <math>x &gt; 0</math> and <math>f(x) = 0</math> for <math>x &lt; 0</math>.</li> <li><b>Team Work:</b> What are the conditions for the existence of Fourier Transform of a function <math>f(x)</math> and write at least two applications of Fourier transform in engineering domain. Sketch the function and its transform using any mathematical software.</li> </ol>
5	<ol style="list-style-type: none"> <li>Find Z- transform of the function <math>\sin(3n + 5)</math>.</li> <li>Find the Z- transform and region of convergence of <math>u(n) = {}^n C_k, n \geq k</math>.</li> <li><b>Team Work:</b> Create a group of at least 8 students and identify an application of Z-transform in real life. Solve the problem using any mathematical software and comment on the result. Prepare a short report.</li> </ol>

24CYP203	ENGINEERING CHEMISTRY (Circuit Branches)	L	T	P	J	S	C	Year of Introduction 2024
		2	1	2	0	4	4	

**Preamble:** Enable the students to build a solid foundation in fundamentals of chemistry, to correlate theoretical concepts with their industrial/engineering applications and to get hands-on laboratory experience on the principles discussed in theory sessions. The course imparts knowledge on various important topics like atomic and molecular structure, electrochemistry, etc., as they apply to the field of engineering and to familiarize the students with different application-oriented topics like spectroscopy, molecular electronics, nanomaterials, etc. It helps the learners to prepare them for advanced concepts in chemistry and to do interdisciplinary research.

**Prerequisite:** Higher secondary level Chemistry

**Course Outcomes:** After the completion of the course the student will be able to

<b>CO1</b>	Illustrate molecular orbital energy level diagram of diatomic molecules [Understand level]
<b>CO2</b>	Identify the suitable spectroscopy technique for the characterization of engineering materials and interpret spectral data. [Apply level]
<b>CO3</b>	Design electrochemical cells, compare the working of different electrochemical energy storage devices and describe corrosion control methods [Understand level]
<b>CO4</b>	Use the basic concepts of conducting polymers to design polymer based electronic devices [Apply level]
<b>CO5</b>	Recognize proper synthetic methods and describe applications of nanomaterials in science and engineering [Apply level]
<b>CO6</b>	Interpret molecular/system properties, gain skills to synthesize materials and carryout quantitative chemical analysis [Apply level]

#### CO - PO MAPPING

CO	PO1	PO2	PO3	PO4	PO5	PO6	PO7	PO8	PO9	PO10	PO11	PO12
CO 1	✓											✓
CO 2	✓	✓			✓				✓	✓		✓
CO 3	✓	✓							✓	✓		✓
CO 4	✓	✓							✓	✓		✓
CO 5	✓	✓			✓		✓		✓	✓		✓
CO 6	✓	✓			✓			✓	✓	✓		✓

#### Assessment Pattern for Theory component

Bloom's Category	Continuous Assessment Tools			End Semester Examination
	Test1	Test 2	Other tools	
Remember	✓	✓	✓	✓
Understand	✓	✓	✓	✓
Apply	✓	✓	✓	✓
Analyse				
Evaluate				
Create				

<b>Assessment Pattern for Lab component</b>							
<b>Bloom's Category</b>		<b>Continuous Assessment Tools</b>					
		<b>Class work</b>			<b>Test1</b>		
Remember							
Understand		✓				✓	
Apply		✓				✓	
Analyse							
Evaluate							
Create							
<b>Mark Distribution of CIA</b>							
<b>Course Structure [L-T-P-J]</b>	<b>Attendance</b>	<b>Theory [L- T]</b>			<b>Practical [P]</b>		<b>Total Marks</b>
		<b>Assignment</b>	<b>Test-1</b>	<b>Test-2</b>	<b>Class work</b>	<b>Lab Exam</b>	
<b>2-1-2-0</b>	5	10	12.5	12.5	10	10	60
<b>Total Marks distribution</b>							
<b>Total Marks</b>	<b>CIA (Marks)</b>	<b>ESE (Marks)</b>			<b>ESE Duration</b>		
100	60	40			2.5 hours		
<b>End Semester Examination [ESE]: Pattern</b>							
<b>PATTERN</b>	<b>PART A</b>		<b>PART B</b>			<b>ESE Marks</b>	
PATTERN 2			2 questions will be given from each module, out of which 1 question should be answered. Each question can have a maximum of 2 sub divisions. Each question carries 8 marks. Marks: (5x 8 = 40 marks) Time: 2.5 hours			40	
	Total Marks: 0		Total Marks: [5x8 = 40 marks]				
<b>SYLLABUS</b>							
<b>MODULE I: ATOMIC AND MOLECULAR STRUCTURE</b>							
Atomic and molecular orbitals - Postulates of molecular orbital theory - Linear Combination of Atomic Orbitals (LCAO) - Molecular orbitals of diatomic molecules - Molecular orbital energy level diagrams of N <sub>2</sub> and O <sub>2</sub> - Metallic bonding - Limitations of Valence Bond Theory (VBT) - Introduction to Crystal Field Theory (CFT) – Band structure of solids and the role of doping on band structures.							
<b>MODULE II: SPECTROSCOPIC TECHNIQUES AND APPLICATIONS</b>							
Introduction to spectroscopy - Beer Lambert's law (Numericals)- UV-vis spectroscopy (introduction, various electronic transitions and applications)-Vibrational spectroscopy (introduction, Number of vibrational modes of CO <sub>2</sub> and H <sub>2</sub> O, applications) - Surface characterization techniques: introduction and applications of X-ray photoelectron spectroscopy (XPS) and Auger electron spectroscopy (AES) - Diffraction: introduction and applications of X-Ray Diffraction (XRD)							
<b>MODULE III: ELECTROCHEMISTRY AND CORROSION</b>							
Introduction - Differences between electrolytic and electrochemical cells - Daniel cell -							

Redox reactions - Cell representation - Construction and working of Calomel electrode - Electrochemical series and its applications - Nernst Equation (Derivation not required) - Single electrode and cell (Numericals) – Applications - Primary cells and secondary cells with examples - Construction and working of Lithium-ion cell - Introduction to fuel cell - Mechanism of electrochemical corrosion - Galvanic series - Cathodic protection.

#### **MODULE IV: MOLECULAR ELECTRONICS**

Charge transport carriers - soliton, polaron, bipolaron - Conducting polymers - intrinsically and extrinsically conducting polymers - Polyaniline, Polyacetylene, Poly (p-phenylene) and Polypyrrole – Preparation, properties and applications - OLED - Principle, construction and advantages - Photoresist for electronics – Introduction to molecular devices based on conducting polymers (Field-effect transistor, Biosensors)

#### **MODULE V: NANOMATERIALS**

Nanomaterials - Definition - Unique characteristics - Top-down and bottom-up approach for synthesis (Brief explanation) - Chemical methods of preparation - Hydrolysis, Reduction, Chemical vapor deposition (CVD) - Characterization techniques – Principle and instrumentation (block diagram) of Scanning electron Microscope (SEM) and Transmission electron microscope (TEM)- - Introduction and applications of Graphene, Carbon nanotube, Quantum dots, MXenes, Metal organic framework.

#### **Text books**

1. AICTE's Prescribed Textbook: Chemistry – I with Lab Manual, Khanna Book Publishing.
2. Engineering Chemistry, by Manisha Agrawal.
3. University chemistry, by B. H. Mahan.
4. Chemistry: Principles and Applications, by M. J. Sienko and R. A. Plane.
5. Fundamentals of Molecular Spectroscopy, by C. N. Banwell.
6. Engineering Chemistry (NPTEL Web-book), by B. L. Tembe, Kamaluddin and M. S. Krishnan.
7. Physical Chemistry, by P. W. Atkins.
8. A Textbook of Engineering Chemistry, Shashi Chawla
9. NANO: The Essentials: Understanding Nanoscience and Nanotechnology, by T. Pradeep

#### **Reference books**

1. Muhammed Arif, Annette Fernandez, Kavitha P. Nair, Engineering Chemistry, Owl Books, 2019.
2. Ahad J., Engineering Chemistry, Jai Publication, 2019.
3. Roy K. Varghese, Engineering Chemistry, Crownplus Publishers, 2019.
4. Soney C. George & Rino Laly Jose, Text Book of Engineering Chemistry, S. Chand & Company Pvt Ltd, 2019.
5. Jain and Jain, Engineering Chemistry, DhanpatRai Publishers, 17th Edition, 2018.
6. Wiley India, Engineering Chemistry, ISBN 9788126543205

### **COURSE CONTENTS AND LECTURE SCHEDULE**

No.		No. of Hours
<b>MODULE 1</b>		
1.1	Atomic and molecular orbitals - Postulates of molecular orbital theory	1

1.2	Linear Combination of Atomic Orbitals (LCAO)	1
1.3	Molecular orbitals of diatomic molecules- Molecular orbital energy level diagrams of N <sub>2</sub>	1
1.4	Molecular orbital energy level diagrams of O <sub>2</sub>	1
1.5	Metallic bonding - Limitations of Valence Bond Theory (VBT)	1
1.6	Introduction to Crystal Field Theory (CFT)	1
1.7	Band structure of solids	1
1.8	Role of doping on band structures	1
<b>MODULE II</b>		
2.1	Introduction to spectroscopy	1
2.2	Beer Lambert's law (Numericals), UV-vis spectroscopy -introduction	1
2.3	Various electronic transitions – applications	1
2.4	Vibrational spectroscopy - introduction,	1
2.5	Number of vibrational modes of CO <sub>2</sub> and H <sub>2</sub> O - applications	1
2.6	Surface characterization techniques: introduction and applications of X-ray photoelectron spectroscopy (XPS) and Auger electron spectroscopy (AES)	1
2.7	Diffraction: introduction and applications of X-Ray Diffraction (XRD)	1
<b>MODULE III</b>		
3.1	Introduction - Differences between electrolytic and electrochemical cells - Daniel cell - Redox reactions	1
3.2	Cell representation - Construction and working of Calomel electrode	1
3.3	Electrochemical series and its applications	1
3.4	Nernst Equation (derivation not required) - Single electrode and cell (Numericals) – Applications	1
3.5	Primary cells and secondary cells with examples - Construction and working of Lithium-ion cell	1
3.6	Introduction to fuel cell - Mechanism of electrochemical corrosion	1
3.7	Galvanic series - cathodic protection.	1
<b>MODULE IV</b>		
4.1	Charge transport carriers - soliton, polaron, bipolaron	1
4.2	Conducting polymers - intrinsically and extrinsically conducting polymers	1
4.3	Polyaniline, Polyacetylene, Poly (p-phenylene) and Polypyrrole – Preparation, properties and applications	1
4.4	OLED - Principle, construction and advantages	1
4.5	Photoresist for electronics	1
4.6	Introduction to molecular devices based on conducting polymers	1
4.7	Field-effect transistor, Biosensors	1
<b>MODULE V</b>		
5.1	Nanomaterials - Definition - Unique characteristics	1

5.2	Top-down and bottom-up approach for synthesis (brief explanation) - Chemical methods of preparation - Hydrolysis	1
5.3	Chemical methods of preparation - Reduction, Chemical vapor deposition (CVD)	1
5.4	Characterization techniques – Principle and instrumentation (block diagram) of Scanning electron Microscope (SEM)	1
5.5	Principle and instrumentation (block diagram) of Transmission electron microscope (TEM)	1
5.6	Introduction and applications of Graphene, Carbon nanotube	1
5.7	Introduction and applications of Quantum dots, MXenes, Metal organic framework	1

**LESSON PLAN FOR LAB COMPONENT  
(Any 7 experiments to be conducted)**

No.	Topic	No. of Hours	Experiment
1	Electrochemistry	10	Experiment 1: Estimation of iron from iron ore/alloy Experiment 2: Determination of cell constant and conductivity of solutions Experiment 3: Potentiometric redox titration Experiment 4: Calibration of pH meter and determination of pH of solutions Experiment 5: Determination of pKa of weak acid using pH meter
2	Spectroscopy	4	Experiment 6: Analysis of IR spectra (minimum 3 spectra) Experiment 7: Analysis of XPS, AES, XRD spectra (minimum 3 spectra)
3	Synthesis of polymer and nanomaterial	8	Experiment 8: Synthesis of urea-formaldehyde Experiment 9: Synthesis of polyaniline Experiment 10: Synthesis of silver nanoparticles using chemical reduction method Experiment 11: Biogenic Synthesis of Silver Nanoparticles using plant extract
4	Water Chemistry	6	Experiment 12: Estimation of hardness of water by EDTA method Experiment 13: Determination of chloride content of water. Experiment 14: Determination of total alkalinity of water sample
5	Others	8	Experiment 15: Estimation of copper in brass Experiment 16: Identification of components in a mixture using TLC Experiment 17: Chemical analysis of a salt. Experiment 18: Chemical oscillations- Iodine clock reaction.

**CO Assessment Questions**

1	Illustrate why the molecular orbital energy level diagram for O <sub>2</sub> is different from N <sub>2</sub>
2	<p>a) Choose a molecule. Find its IR spectrum from the web using any one of the following sources (i) AIST: Spectral Database for Organic Compounds (SDBS), <a href="https://sdb.db.aist.go.jp/sdb/cgi-bin/cre_index.cgi">https://sdb.db.aist.go.jp/sdb/cgi-bin/cre_index.cgi</a> (ii) NIST chemistry webbook, <a href="https://webbook.nist.gov/chemistry/">https://webbook.nist.gov/chemistry/</a> (iii) Sigma Aldrich, <a href="https://www.sigmaaldrich.com/IN/en">https://www.sigmaaldrich.com/IN/en</a> (iv) KnowItAll, <a href="https://www.knowitallanyware.com/#search">https://www.knowitallanyware.com/#search</a>.</p> <p>Interpret the spectrum in your own words highlighting how you can elucidate the structure of the molecule of your choice from the spectrum.</p> <p>b) Compare XPS and AES techniques and identify when each testing method is used.</p>
3	<p>a) Write the cell reactions of the following cell. Cd/CdSO<sub>4</sub>(0.01)//CuSO<sub>4</sub>(0.5M)/Cu. Sketch the electrochemical cell.</p> <p>b) Prepare a presentation on the topic “Energy storage devices; past, present and future”</p> <p>c) Write a report on the topic “Corrosion Control in Industry”</p>
4	<p>a) Prepare a table comparing various charge transport carriers in polymers</p> <p>b) Prepare a power point presentation on conducting polymer-based biosensors</p>
5	<p>a) Compare top-down and bottom-up methods for nanomaterial synthesis.</p> <p>b) Write a report on the role of nanotechnology in your branch of engineering</p> <p>c) Group discussion on “can nanotechnology offer solutions to environmental issues”</p>
6	<p>a) Estimate the amount of iron from iron ore using volumetric and potentiometric titrations, compare the results and identify which technique is more accurate.</p> <p>b) Collect water from three different sources. Measure their conductivity and pH and interpret the results.</p>

24ESP204	<b>PROBLEM SOLVING AND PROGRAMMING</b>						<b>L</b>	<b>T</b>	<b>P</b>	<b>J</b>	<b>S</b>	<b>C</b>	<b>Year of Introduction</b>
							3	0	2	0	5	4	2024
<p><b>Preamble:</b> This course enables students to acquire problem solving and programming skills to solve computational problems. This course covers Basics of Computer Hardware and Software, C Programming basics, arrays, strings, structure, union, functions, pointers and files. This course helps the learners to think logically, computationally and creatively to solve real world problems.</p>													
<b>Prerequisite: Nil</b>													
<b>Course Outcomes:</b> After the completion of the course the student will be able to													
<b>CO 1</b>	Formulate simple algorithms/flowcharts for arithmetic and logical problems using appropriate tools.[Apply level]												
<b>CO 2</b>	Implement conditional branching, iteration and recursion.[Understand level]												
<b>CO 3</b>	Use arrays, pointers and structures to formulate algorithms and implement programs.[Understand level]												
<b>CO 4</b>	Decompose a problem into functions and synthesize a complete program using divide and conquer approach.[Understand level]												
<b>CO 5</b>	Develop readable C programs with files for reading input and storing output.[Understand level]												
<b>CO 6</b>	Test and execute the programs by correcting syntax and logical errors.[Understand level]												
<b>CO - PO MAPPING</b>													
<b>CO</b>	<b>P01</b>	<b>P02</b>	<b>P03</b>	<b>P04</b>	<b>P05</b>	<b>P06</b>	<b>P07</b>	<b>P08</b>	<b>P09</b>	<b>P010</b>	<b>P011</b>	<b>P012</b>	
<b>CO 1</b>	✓	✓			✓			✓				✓	
<b>CO 2</b>	✓	✓						✓				✓	
<b>CO 3</b>	✓	✓						✓				✓	
<b>CO 4</b>	✓	✓						✓				✓	
<b>CO 5</b>	✓	✓						✓				✓	
<b>CO 6</b>	✓	✓						✓				✓	



<b>Assessment Pattern for Theory component</b>							
<b>Bloom's Category</b>	<b>Continuous Assessment Tools</b>			<b>End Semester Examination</b>			
	<b>Test1</b>	<b>Test 2</b>	<b>Other tools</b>				
Remember	✓	✓	✓	✓			
Understand	✓	✓	✓	✓			
Apply	✓	✓	✓	✓			
Analyse			✓				
Evaluate			✓				
Create			✓				
<b>Assessment Pattern for Lab component</b>							
<b>Bloom's Category</b>	<b>Continuous Assessment Tools</b>						
	<b>Class work</b>	<b>Test1</b>					
Remember							
Understand	✓	✓					
Apply	✓	✓					
Analyse	✓	✓					
Evaluate	✓						
Create	✓						
<b>Mark Distribution of CIA</b>							
<b>Course Structure [L-T-P-J]</b>	<b>Attendance</b>	<b>Theory [L- T]</b>			<b>Practical [P]</b>		<b>Total Marks</b>
		<b>Assignment</b>	<b>Test-1</b>	<b>Test-2</b>	<b>Class work</b>	<b>Lab Exam</b>	
3-0-2-0	5	10	12.5	12.5	10	10	60

<b>Total Marks distribution</b>			
<b>Total Marks</b>	<b>CIA (Marks)</b>	<b>ESE (Marks)</b>	<b>ESE Duration</b>
100	60	40	2.5 Hours

**End Semester Examination [ESE]: Pattern**

<b>PATTERN</b>	<b>PART A</b>	<b>PART B</b>	<b>ESE Marks</b>
PATTERN 2		2 questions will be given from each module, out of which 1 question should be answered. Each question can have a maximum of 2 sub divisions.  Each question carries 8 marks.  Marks: (5x 8 = 40 marks)  Time: 2.5 hours	40
	Total Marks: 0	Total Marks: [5x8 = 40 marks]	

**SYLLABUS**

**MODULE I : Basics of Computer Hardware and Software (7 hours)**

Basics of Computer Architecture: Processor, Memory, Input& Output devices. Application Software & System software: Compilers, interpreters, High level and low level languages, Introduction to structured approach to programming, Flow chart, Algorithms, Pseudo code (bubble sort, linear search - algorithms and pseudocode).

**MODULE II : Program Basics (8 hours)**

Basic structure of C program: Character set, Tokens, Identifiers in C, Variables and Data Types, Constants, Console IO Operations, printf and scanf. Operators and Expressions: Expressions and Arithmetic Operators, Relational and Logical Operators, Conditional operator, size of operator, Assignment operators and Bitwise Operators, Operators Precedence. Control Flow Statements: If Statement, Switch Statement, Unconditional Branching using goto statement, While Loop, Do While Loop, For Loop, Break and Continue statements.(Simple programs covering control flow).

**MODULE III : Arrays and strings (7 hours)**

Arrays Declaration and Initialization, 1-Dimensional Array, 2-Dimensional Array. String processing: In built String handling functions (strlen, strcpy, strcat and strcmp, puts, gets). Linear search program, bubble sort program, simple programs covering arrays and strings.

**MODULE IV : Working with functions (7 hours)**

Introduction to modular programming, writing functions, formal parameters, actual parameters, Pass by Value, Recursion, Arrays as Function Parameters structure, union, Storage Classes, Scope and life time of variables, simple programs using functions.

**MODULE V : Pointers and Files (7 hours)**

Basics of Pointer: Declaring pointers, accessing data through pointers, NULL pointer, array access using pointers, pass by reference effect. File Operations: open, close, read, write, append. Sequential access and random access to files: In built file handling functions (rewind() ,fseek(), ftell(), feof(), fread(), fwrite()), simple programs covering pointers and files.

**Text books**

1. Schaum's Outline of Programming with C, Byron Gottfried, Jitender Chhabra Tata McGraw Hill, 2005.
2. Programming in ANSI C, E. Balagurusamy, Mcgraw Hill, 2019.
3. Programming in C, Asok N Kamthane, Pearson Education, 2015.
4. Computer Fundamentals, Anita Goel, Pearson Education.

**References**

1. Computer fundamentals and Programming in C, Anita Goel and Ajay Mittal, Pearson Education, 2016.
2. The C Programming Language, Brian W. Kernighan and Dennis M. Ritchie, Pearson Education, 2015
3. Computer Basics and Programming in C, Rajaraman V, PHI, 2007.
4. Let us C, Yashavant Kanetkar, BPB Publications, 2016.

**NPTEL/SWAYAM Courses**

1. Introduction To Programming In C, Prof. Satyadev Nandakumar IIT Kanpur.
2. Problem Solving Through Programming In C, Prof. Anupam Basu IIT Kharagpur.

**COURSE CONTENTS AND LECTURE SCHEDULE**

No.		No. of Hours
<b>MODULE 1</b>		
1.1	Basics of Computer Architecture: Processor	1 Hour
1.2	Basics of Computer Architecture: Memory	1 Hour
1.3	Basics of Computer Architecture: Input& Output devices	1 Hour
1.4	Application Software & System software: Compilers, interpreters, High level and low level languages	1 Hour
1.5	Introduction to structured approach to programming, Flow chart	1 Hour
1.6	Algorithms, Pseudo code	1 Hour

1.7	Bubble sort, linear search - algorithms and pseudocode	1 Hour
<b>MODULE II</b>		
2.1	Basic structure of C program: Character set, Tokens, Identifiers in C	1 Hour
2.2	Basic structure of C program: Variables and Data Types , Constants, Console IO Operations, printf and scanf	1 Hour
2.3	Operators and Expressions: Expressions and Arithmetic Operators, Relational and Logical Operators.	1 Hour
2.4	Operators and Expressions: Conditional operator, size of operator, Assignment operators and Bitwise Operators. Operators Precedence	1 Hour
2.5	Control Flow Statements: If Statement, Unconditional Branching using goto statement.(Simple programs covering control flow)	1 Hour
2.6	Control Flow Statements: Switch Statement, Break statement.(Simple programs covering control flow)	1 Hour
2.7	Control Flow Statements: While Loop, Do While Loop (Simple programs covering control flow)	1 Hour
2.8	Control Flow Statements: For Loop, Continue statement.(Simple programs covering control flow)	1 Hour
<b>MODULE III</b>		
3.1	Arrays Declaration and Initialization, 1-Dimensional Array, Simple programs covering 1 – Dimensional Array	1 Hour
3.2	Arrays Declaration and Initialization, 2-Dimensional Array , Simple programs covering 2 – Dimensional Array	1 Hour
3.3	Arrays -2- Programs covering 1 and 2 – Dimensional Arrays	1 Hour
3.4	String processing: In built String handling functions(strlen, strcpy, strcat and strcmp, puts, gets)	1 Hour
3.5	Linear search program- Implementation	1 Hour
3.6	Bubble sort program- Implementation	1 Hour
3.7	Simple programs covering arrays and strings	1 Hour
<b>MODULE IV</b>		
4.1	Introduction to modular programming - writing functions	1 Hour
4.2	Writing functions with formal parameters and actual parameters	1 Hour

4.3	Writing functions with Pass by Value and Recursion	1 Hour
4.4	Writing functions with arrays as Function Parameters	1 Hour
4.5	Structure and union	1 Hour
4.6	Storage Classes, Scope and life time of variables	1 Hour
4.7	Simple programs using functions	1 Hour
<b>MODULE V</b>		
5.1	Basics of Pointers: declaring pointers	1 Hour
5.2	Pointers: accessing data through pointers, NULL pointer, simple programs	1 Hour
5.3	Pointers: Array access using pointers, pass by reference effect, simple programs	1 Hour
5.4	File Operations: open, close, read, write, append	1 Hour
5.5	Programs using file operations	1 Hour
5.6	Sequential access and random access to files: In built file handling functions (rewind() ,fseek(), ftell(), feof(), fread(), fwrite()),	1 Hour
5.7	Sequential access and random access to files: Simple programs	1 Hour

### LESSON PLAN FOR LAB COMPONENT

No.	Topic	No. of Hours	Experiment
1	Basics of Computer Architecture: Processor, Memory, Input & Output devices	1	Familiarization of Hardware Components of a Computer
2	Application Software & System software: Compilers, interpreters, High level and low level languages	1	Familiarization of Linux environment – How to do Programming in C with Linux
3	Introduction to structured approach to programming, Flow chart	2	Familiarization of Tools - Flowgorithm and Raptor. Develop flowcharts and algorithms for a set of given problems
4	Basic structure of C program: Character set, Tokens, Identifiers	1	Familiarization of console I/O and operators in C

	in C, Variables and Data Types , Constants, Console IO Operations, printf and scanf		<ul style="list-style-type: none"> <li>i) Display "Hello World"</li> <li>ii) Read two numbers, add them and display their sum</li> <li>iii) Read the radius of a circle, calculate its area and display it</li> <li>iv) Evaluate the arithmetic expression <math>((a - b / c * d + e) * (f + g))</math> and display its solution. Read the values of the variables from the user through console.</li> </ul>
5	Operators and Expressions: Expressions and Arithmetic Operators, Relational and Logical Operators, Conditional operator, sizeof operator, Assignment operators and Bitwise Operators. Operators Precedence	1	<ul style="list-style-type: none"> <li>i) Read 3 integer values and find the largest among them.</li> <li>ii) Read a Natural Number and check whether the number is prime or not</li> </ul>
6	Control Flow Statements: If Statement, Switch Statement, Unconditional Branching using goto statement, While Loop, Do While Loop, For Loop, Break and Continue statements.	1	<ul style="list-style-type: none"> <li>iii) Read a Natural Number and check whether the number is Armstrong or not</li> </ul>
7	Arrays Declaration and Initialization, 1-Dimensional Array, 2-Dimensional Array	1	<ul style="list-style-type: none"> <li>i) Read n integers, store them in an array and find their sum and average</li> <li>ii) Read n integers, store them in an array and search for an element in the array using an algorithm for Linear Search</li> </ul>
	Linear search program, bubble sort program	1	<ul style="list-style-type: none"> <li>iii) Read n integers, store them in an array and sort the elements in the array using Bubble Sort algorithm</li> </ul>
8	String processing: In built String handling functions(strlen, strcpy, strcat and strcmp, puts, gets)	2	<ul style="list-style-type: none"> <li>i) Read a string (word), store it in an array and check whether it is a palindrome word or not.</li> <li>ii) Read two strings (each one</li> </ul>

			<p>ending with a \$ symbol), store them in arrays and concatenate them without using library functions</p> <p>iii) Read a string (ending with a \$ symbol), store it in an array and count the number of vowels, consonants and spaces in it.</p>
9	Introduction to modular programming, writing functions, formal parameters, actual parameters	2	<p>i) Find the factorial of a given Natural Number n using recursive and non recursive functions</p> <p>ii) Read a string (word), store it in an array and obtain its reverse by using a user defined function.</p> <p>iii) Write a menu driven program for performing matrix addition, multiplication and finding the transpose. Use functions to</p> <p>(a) read a matrix,</p> <p>(b) find the sum of two matrices, (c) find the product of two matrices,</p> <p>(d) find the transpose of a matrix and</p> <p>(e) display a matrix.</p>
	Pass by Value, Recursion, Arrays as Function Parameters	2	
10	Structure, union, Storage Classes, Scope and life time of variables, simple programs using functions	2	<p>i) Read two input each representing the distances between two points in the Euclidean space, store these in structure variables and add the two distance values.</p> <p>ii) Using structure, read and print data of n employees (Name, Employee Id and Salary)</p> <p>iii) Declare a union containing 5 string variables (Name, House Name, City Name, State and Pin code) each</p>

			with a length of C_SIZE (user defined constant). Then, read and display the address of a person using a variable of the union.
11	Basics of Pointers: declaring pointers, accessing data through pointers, NULL pointer, array access using pointers, pass by reference effect	3	<p>i) Do the following using pointers</p> <p>(a) add two numbers</p> <p>(b) swap two numbers using a user defined function</p> <p>ii) Input and Print the elements of an array using pointers</p> <p>iii) Compute sum of the elements stored in an array using pointers and user defined function.</p>
12	File Operations: open, close, read, write, append	2	i) Create a file and perform the following
13	Sequential access and random access to files: In built file handling functions (rewind(), fseek(), ftell(), feof(), fread(), fwrite())	2	<p>(a) Write data to the file</p> <p>(b) Read the data in a given file &amp; display the file content on console</p> <p>(c) append new data and display on console</p> <p>ii) Open a text input file and count number of characters, words and lines in it; and store the results in an output file.</p>

### CO Assessment Questions

1	<p>Write an algorithm and draw flowchart (using Flowgorithm/Raptor)</p> <p>a) To find the roots of a quadratic equation</p> <p>b) To check whether largest of 3 natural numbers is prime or not</p> <p>c) To sort a set of numbers</p>
2	<p>Develop a C program</p> <p>a) To process a set of n natural numbers and to find the largest even number and smallest odd number from the given set of numbers. The program should not use division and modulus operators.</p>



	<p>b) To find the value of a mathematical function <math>f</math> which is defined as follows. <math>f(n) = n! / (\text{sum of factors of } n)</math>, if <math>n</math> is not prime and <math>f(n) = n! / (\text{sum of digits of } n)</math>, if <math>n</math> is prime.</p> <p>c) To evaluate the series <math>x - x^2/2! + x^3/3! - \dots</math> <math>n</math> terms, for a given values of <math>x</math> and <math>n</math>.</p>
3	<p>Write a C program</p> <p>a) To sort a set of <math>n</math> integers and to find the number of unique numbers and the number of repeated numbers in the given set of numbers. Use a function which takes an integer array of <math>n</math> elements, sorts the array using the Bubble Sorting Technique and returns the number of unique numbers and the number of repeated numbers in the given array.</p> <p>b) To read and multiply two matrices using pointers</p> <p>c) To process the marks obtained by <math>n</math> students of a class and prepare their rank list based on the sum of the marks obtained. There are 3 subjects for which examinations are conducted and the third subject is an elective where a student is allowed to take any one of the two courses offered.</p>
4	<p>Write a menu driven program to</p> <p>a) Read a matrix, display a matrix, add two matrices, multiply two matrices, check symmetry and transpose a matrix.</p> <p>b) To read the details of a set of students, display the details of all students, sort the details based on roll number, search for a student using name</p>
5	<p>Write a C program to</p> <p>a) Process a text file and to print the Palindrome words into an output file.</p> <p>b) Store the details of books in a library using a file and perform updation, deletion and insertion of a book from on the file based on title</p>
6	<p>Test and execute the above programs using a C Compiler.</p>

24EST108/ 24EST206	ENGINEERING GRAPHICS	L	T	P	J	S	C	Year of Introduction 2024
		2	2	0	0	2	4	

**Preamble:** Practicing Engineers require conversion of ideas and design into new products or in interpreting information from existing drawings. The course in Engineering Graphics deals with orthographic / pictorial projections, dimensioning and specifications, sectional views, isometric projection, development of surfaces and use of CAD software in preparing drawings. It enables the students to acquire basic knowledge about Engineering drawing and prepare themselves for a career in Engineering.

**Prerequisite:** Nil

**Course Outcomes:** After the completion of the course the student will be able to

<b>CO1</b>	Generate orthographic projections of lines inclined to one or both reference planes, ensuring accurate representation of their true length and orientation.
<b>CO2</b>	Construct orthographic projections of solids with axes inclined to one or both reference planes, demonstrating an understanding of their spatial orientation and dimensions.
<b>CO3</b>	Create sectional views of various solids, including prisms, pyramids, cones, and cylinders when cut by different section planes.
<b>CO4</b>	Create developed surfaces of solids that have been cut by different section planes.
<b>CO5</b>	Prepare pictorial drawings using the principles of isometric projection to visualize objects in three dimensions and convert isometric views to orthographic views.
<b>CO6</b>	Prepare multi-view orthographic projections of 3D solids using CAD tools by visualizing them in different positions.

**CO - PO MAPPING**

CO	PO1	PO2	PO3	PO4	PO5	PO6	PO7	PO8	PO9	PO10	PO11	PO12
CO 1	3											
CO 2	3											
CO 3	3											
CO 4	3											
CO 5	3									3		2
CO 6	3				3					3		2

**Assessment Pattern for Theory component**

Bloom's Category	Continuous Assessment Tools			End Semester Examination
	Test1	Test 2	Other tools	
Remember	✓	✓	✓	✓
Understand	✓	✓	✓	✓
Apply	✓	✓	✓	✓
Analyse				
Evaluate				
Create				

**Assessment Pattern for Lab component**

Bloom's Category	Continuous Assessment Tools	
	Class work	Test1
Remember		
Understand	✓	✓
Apply	✓	✓
Analyse		

Evaluate					
Create					
<b>Mark Distribution of CIA</b>					
Course Structure [L-T-P-J]	Attendance	Theory [L- T]			Total Marks
		Assignment	Test-1	Test-2	
<b>2-2-0-0</b>	5	10	12.5	12.5	<b>40</b>
<b>Total Marks distribution</b>					
Total Marks	CIA (Marks)	ESE (Marks)		ESE Duration	
100	40	60		3 hrs	
<b>End Semester Examination [ESE]: Pattern</b>					
PATTERN	PART A	PART B			ESE Marks
PATTERN 3		2 questions will be given from each module, out of which 1 question should be answered.  Each question carries 12 marks.  Marks: (5x 12 = 60 marks)  Time: 3 hours			60
	Total Marks: 0	Total Marks: [5x12 = 60 marks]			
<b>SYLLABUS</b>					
<b>MODULE I: Introduction to Engineering Drawing &amp; Orthographic Projections</b>					
Principles of Engineering Graphics and their significance, usage of Drawing instruments, lettering, Dimensioning. Principles of Orthographic Projections- Conventions - Projections of Points and projection of lines parallel to/inclined to both reference planes. Traces of lines.					
<b>MODULE II: Projections of Regular Solids</b>					
Projection of solids-Prisms, pyramids, solids of revolution-cone, cylinder. Solids with axis parallel to/ inclined to both the reference Planes- Auxiliary Views.					
<b>MODULE III: Sections and Sectional Views of Right Angular Solids</b>					
Sections of Solids: Sections of Prisms, Pyramids, Cone, Cylinder with axis in vertical position and cut by different section planes. True shape of the sections. Also locating the section plane when the true shape of the section is given.					
<b>MODULE IV: Development of Surfaces</b>					
Development of Surfaces: Development of surfaces of the Prisms, Pyramids, Cone, Cylinder with axis in vertical position, development of surfaces of solids cut by different section planes. Shortest distance between two points on the surface.					
<b>MODULE V: Isometric Projections &amp; 2D Drafting using software</b>					
Isometric Projection: Isometric View and Projections of Prisms, Pyramids, Cone , Cylinder, Frustum of Pyramid, Frustum of Cone, Sphere, Hemisphere and their combinations. Conversion of Isometric Views to Orthographic Views.					

**AutoCAD (Internal Evaluation only)**

Demonstrating knowledge of a 2D drafting software - Toolbars (Standard, Object Properties, Draw, Modify and Dimension), Prepare orthographic views of 3 D objects from their isometric views.

**Text books**

1. P. I. Varghese, Engineering Graphics, Tata McGraw Hill Education
2. Prof. J Benjamin, Engineering Graphics, Pentex Publishers

**Reference books**

1. N. D. Bhatt, Engineering Drawing, Charotar Publishing House
2. <https://nptel.ac.in/courses/112/103/112103019> (MOOC Course)

**COURSE CONTENTS AND LECTURE SCHEDULE**

No.		No. of Hours[44]
<b>MODULE 1[10]</b>		
1.1	Principles of Engineering Graphics and their significance, usage of Drawing instruments, lettering, Dimensioning	1
1.2	Principles of Orthographic Projections-Conventions - Projections of Points	1
1.3	Projections of Points (Problems on projection of points)	1
1.4	Projection of lines parallel to/inclined to one reference plane.	1
1.5	Projection of lines inclined to both reference planes. Line rotation method	1
1.6	Problem on lines inclined to both planes	1
1.7	Problem on lines inclined to both planes when apparent lengths are given.	1
1.8	Traces of lines using line rotation.	1
1.9	Problems on Lines using plane rotation method	1
1.10	Problems on Lines when traces are given.	1
<b>MODULE II [12]</b>		
2.1	Projection of solids- Prisms, pyramids - simple position	1
2.2	Projection of solids- Cylinder, cone - simple position	1
2.3	Projection of solids-Prisms and cylinder inclined to one plane.	1
2.4	Projection of solids-pyramid and cones inclined to one plane.	1
2.5	Projection of solids-Prisms inclined to both the reference Planes	1
2.6	Projection of solids-Pyramids inclined to both the reference Planes	1
2.7	Projection of solids-Cone inclined to both the reference Planes	1
2.8	Projection of solids-Cylinders inclined to both the reference Planes	1
2.9	Problems on projection of solids inclined to both planes.	2
2.10	Solids resting on VP	2
<b>MODULE III [7]</b>		
3.1	Introduction to section- Types of section planes -Sectional orthographic view of Prism when section plane perpendicular to VP inclined to HP	1

3.2	Sectional orthographic view of Pyramid when section plane perpendicular to VP inclined to HP	1
3.3	Sectional orthographic view of prism and Cylinder when section plane perpendicular to VP inclined to HP	1
3.4	Sectional orthographic view of Cone when section plane perpendicular to VP inclined to HP	1
3.5	Sectional orthographic view of above solids when section plane perpendicular to HP inclined to VP	1
3.6	Problems on Sectional orthographic view of above solids when true shape of the section is given	2
<b>MODULE IV [7]</b>		
4.1	Development of surfaces of Right Regular Solids – Prism.	1
4.2	Development of surfaces of Pyramid.	1
4.3	Problems on development of Prism and Pyramid for sectional solids.	2
4.4	Development of surfaces of Right Regular Solid- Cone and Cylinder.	1
4.5	Problems on development showing shortest path.	2
<b>MODULE V [8]</b>		
5.1	Principles of Isometric Projection-Isometric Scale-Isometric view	1
5.2	Isometric view of simple solids (Pyramids and Prisms)	1
5.3	Isometric view of simple solids (Cylinder and Cone)	1
5.4	Isometric projection of above solids	1
5.5	Isometric projection of Compound solids.	2
5.6	Conversion of Isometric Views to Orthographic Views.	2
<b>Total Hours</b>		<b>44</b>

### LESSON PLAN FOR LAB COMPONENT

No.	Topic	No. of Hours	Experiment
1	Familiarization with AutoCAD commands and tools	2	Auto CAD drawing of Simple geometries
2	Dimensioning, conversion of isometric views in to orthographic views using AutoCAD	2	Conversion of simple components to orthographic views

### CO Assessment Questions

CO1	<ol style="list-style-type: none"> <li>A line AB inclined at <math>40^\circ</math> to HP has its ends 50mm and 20mm above the HP. The length of its elevation is 65mm and its VT is 10 mm above the VP. Determine the true length of AB, its inclination with HP and its HT. How far the point HT from the X-Y line.</li> <li>The end P of a line PQ is 30mm in front of VP and 40 mm above HP, while Q is behind VP and 10 mm above HP. The distance between</li> </ol>
-----	--

	<p>projectors is 70mm. if the line joining the top views makes an angle of <math>45^\circ</math> with the XY line. Draw the projections and find (i) True length (ii) True inclinations (iii) locate the traces.</p> <p>3. Two LED lights are to be fixed on a badminton court. The lights are 1m and 6 m away from a fixed vertical wall and 6m and 5m above the floor respectively. The distance between the lights measured parallel to the wall is 7m. Draw the projections assuming the wall as VP and the floor as HP. Also, find the actual length of the wire required to connect the two LED lights. Use a suitable scale.</p>
CO2	<p>1. A square prism of base side 30mm and length 50mm has a base edge on HP, axis inclined at <math>35^\circ</math> to HP. The base edge on which it rests is inclined <math>45^\circ</math> to VP. Draw the projections of solid.</p> <p>2. A hexagonal pyramid having a base with a 30mm side and a 50mm long axis rests on one of its base corners on the ground with axis inclined at <math>45^\circ</math> to the HP. Draw the projections when the vertical plane containing the axis and the corner makes <math>30^\circ</math> with the VP.</p> <p>3. The trophy to be given to the winners of the football tournament has a frustum of a hexagonal pyramid with the base hexagon of 30mm side, top hexagon of 20mm side and height 80mm. the frustum is placed on top of a square prism of 100mm side and height 20mm. a sphere of radius 28mm is placed centrally on top of the frustum. Draw the plan and elevation of the trophy.</p>
CO3	<p>1. A square prism having a base of 40mm side and 60mm long axis rests on its base on the HP such that one of the vertical faces makes an angle of <math>30^\circ</math> with the VP. A section plane perpendicular to the VP, inclined at <math>45^\circ</math> to the HP and passing through the axis at a point 20mm from its top end, cuts the prism. Draw the front view, sectional top view and true shape of the section.</p> <p>2. A cube with 45mm long edges rests on HP with vertical faces equally inclined to the VP. It is cut by a section plane perpendicular to the VP so that the true shape of the section is a regular hexagon. Draw the sectional top view and the true shape of the section. Determine the inclination of the section plane with the HP.</p>
CO4	<p>1. A cone with a 50 mm base diameter and 70 mm long axis rests on its base on the HP. Draw the development of its lateral surface when it is cut by an auxiliary inclined plane bisecting the axis and inclined at <math>45^\circ</math> to the HP.</p> <p>2. A hexagonal prism having base with a 30mm side and a 70mm axis is resting on its base on the ground with a side of base inclined at <math>45^\circ</math> to the VP. It is cut by an auxiliary inclined plane making an angle of <math>45^\circ</math> with the HP and passing through a point 15 mm below the top end of the axis. Obtain the development of the lateral surface of the truncated prism.</p> <p>3. A sugar jar is in the form of a right circular cone of base diameter 60 mm and height 90 mm and it rests on HP. An ant starts moving from extreme left end of its base, returns to its starting point, after moving</p>

around it. Find geometrically the length of the shortest path the ant can take. Show this in both front and top views.

1. A hemisphere of diameter 80mm is resting on the ground with its flat surface facing upwards. A square pyramid having side of base 40mm and axis 60mm is resting on the base centrally on the top of the hemisphere. Draw the isometric view of the combination of solids.
2. A waste basket is of the shape of a frustum of a hexagonal pyramid with base side 30 cm, top side 50 cm and height 100 cm. Draw the isometric projection of the basket which is standing vertically with smaller hexagonal base on the ground.
3. Using any free software (2D drafting software), prepare the three orthographic views of the machine component shown in figure, following the ISO standards.

CO5

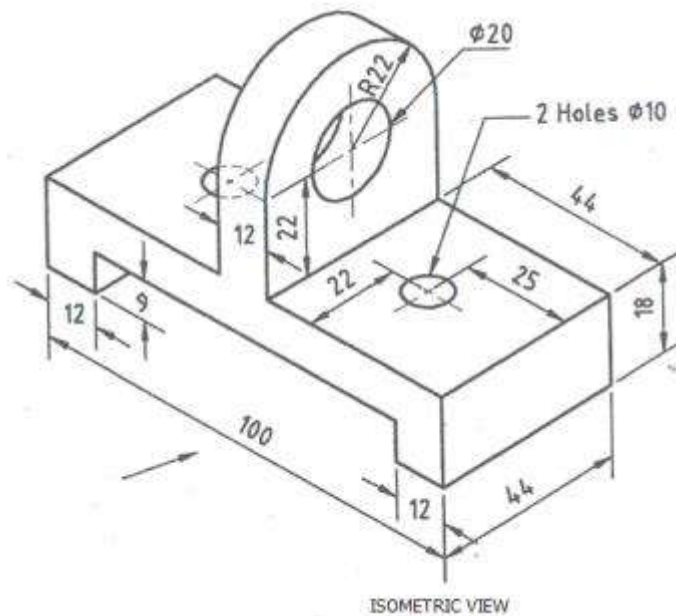

CO6

1. Design a simple pen stand for your study table and draw the three orthographic views of the product using AutoCAD software, following the ISO standards of Engineering drawing and print it on A4 size paper and submit your design.
2. Design a small ornament box and draw the three orthographic views of the product using AutoCAD software, following the ISO standards of Engineering drawing and print it on A4 size paper and submit your design.

<b>24ESL207</b>	<b>MANUFACTURING PRACTICES</b>	<b>L</b>	<b>T</b>	<b>P</b>	<b>J</b>	<b>S</b>	<b>C</b>	<b>Year of Introduction</b>
		<b>0</b>	<b>0</b>	<b>4</b>	<b>0</b>	<b>4</b>	<b>2</b>	<b>2024</b>

**Preamble:** To enable the student to familiarize various tools, measuring devices, practices and different methods of manufacturing processes employed in industry for fabricating components. Topics that give exposure to the hands-on experience on various basic engineering practices in Mechanical, Electrical and Electronics Engineering are included. This helps the learners to apply this experience while developing product/project for the benefit of society.

**Prerequisite:** NIL

**Course Outcomes:** After the completion of the course the student will be able to

<b>CO1</b>	Identify different manufacturing processes which are commonly employed in the industry to fabricate components [Understand level]
<b>CO2</b>	Use appropriate tools and instruments with respect to the mechanical workshop trades and fabricate components as per the design [Apply level]
<b>CO3</b>	Identify the tools used for electrical wiring, accessories, wires, cables, batteries and standard symbols. Execute wiring for simple circuits. [Understand level]
<b>CO4</b>	Develop the schematics and execute simple wiring circuits for domestic buildings. (Apply level)
<b>CO5</b>	Identify and test various electronic components. Fabricate electronic circuits on printed circuit boards and its testing. [Understand level]

**CO - PO MAPPING**

<b>CO</b>	<b>PO1</b>	<b>PO2</b>	<b>PO3</b>	<b>PO4</b>	<b>PO5</b>	<b>PO6</b>	<b>PO7</b>	<b>PO8</b>	<b>PO9</b>	<b>PO10</b>	<b>PO11</b>	<b>PO12</b>
<b>CO1</b>	✓	✓										
<b>CO2</b>	✓	✓							✓	✓		✓
<b>CO3</b>	✓	✓							✓	✓		✓
<b>CO4</b>	✓								✓	✓		✓
<b>CO5</b>	✓								✓	✓		✓

**Assessment Pattern**

<b>Bloom's Category</b>	<b>Continuous Assessment Tools</b>	
	<b>Class work</b>	<b>Test1</b>
Remember		
Understand	✓	✓
Apply	✓	✓
Analyse	✓	✓
Evaluate	✓	
Create	✓	

**Mark Distribution of CIA**

<b>Course Structure [L-T-P-J]</b>	<b>Attendance</b>	<b>Class work</b>	<b>Lab Exam</b>	<b>Total Marks</b>
<b>0-0-4-0</b>	5	55	40	<b>100</b>

**Total Mark distribution**

<b>Total Marks</b>	<b>CIA (Marks)</b>	<b>ESE (Marks)</b>	<b>ESE Duration</b>
	100	0	-



### **SYLLABUS- DETAILS OF EXPERIMENTS**

- Manufacturing Methods- Moulding and casting, and sheet metal
- Conventional Machining (turning, drilling and shaping), CNC Machining
- Fitting operations, Welding (Arc, gas and brazing)
- Carpentry & power tools, Plumbing, Plastic moulding and glass cutting
- Electrical engineering - Study of tools, accessories and safety rules, batteries and earthing, Electrical machines and Transformer. Wiring exercises for simple circuits
- Electronics Engineering – Study of electronic components, instruments, testing of electronic devices. Soldering exercises on PCB and electronic circuits

#### **Text books**

1. Veerana D. K., Workshop / Manufacturing Practices, ISBN 9391505333
2. Robert L.Boylestad' " Electronic Devices and Circuit Theory", Prentice Hall of India, 2007
3. D C Kulshreshtha, "Basic Electrical Engineering", Tata McGraw Hill, 2010

#### **Reference books**

1. Hajra Choudhury S.K., Hajra Choudhury A.K. and Nirjhar Roy S.K., "Elements of Workshop Technology", Vol. I 2008 and Vol. II 2010, Media promoters and publishers private limited, Mumbai.
2. Kalpakjian S. And Steven S. Schmid, "Manufacturing Engineering and Technology", 4<sup>th</sup> edition, Pearson Education India Edition, 2002.
3. Gowri P. Hariharan and A. Suresh Babu," Manufacturing Technology – I" Pearson Education, 2008.
4. Roy A. Lindberg, "Processes and Materials of Manufacture", 4<sup>th</sup> edition, Prentice Hall India, 1998.
5. Rao P.N., "Manufacturing Technology", Vol. I and Vol. II, Tata McGraw Hill House, 2017.
6. <https://archive.nptel.ac.in/courses/112/107/112107219/mooc>
7. Bernard Grob, "Basic Electronics", Tata McGraw Hill, 2000

### **LIST OF EXPERIMENTS**

#### **Mechanical -- 24 Hrs**

<b>No.</b>	<b>Experiments</b>
1	Study and Exercise on foundry. Preparation of mould and making the cast of a given component
2	Study and Exercise on sheet metal. Make the box/can/tray with metal sheet as per the design
3	Study and Exercise on fitting and joining. Prepare the joints and weld together as per the drawing
4	Study and Exercise on Machining Prepare the model as per the drawing using turning, shaping and drilling operations.
5	Study and Exercise on Carpentry. Make simple wooden products like box, rack, etc using power tools.
6	Study and Exercise on plumbing. Do the pipeline assembly as per the sketch
7	Study on CNC Machine, Injection moulding machine, Glass cutting (Demo only)

8	Study on Electric devices and wiring. Exercise on simple wiring for lighting, fan, etc as per the design
9	Study on electronic components and soldering. Exercise on soldering the PCB and circuits as per the given design.

### **ELECTRICAL WORKSHOP -12 Hrs**

1	<ul style="list-style-type: none"> <li>• Introduction to the precautionary steps adopted for Electrical shocks.</li> <li>• Identify the Tools used for Electrical Wiring</li> <li>• Study of Electrical Circuit Symbols and familiarization of wiring Accessories.</li> </ul>
2	Prepare an estimate and Wire-up: A circuit having one light and fan point.
3	Prepare an estimate and Wire-up: A light/fan circuit using two-way switches. (Staircase wiring)
4	Prepare an estimate and Wire-up: A circuit having fluorescent lamp and socket outlet (6A).
5	Prepare an estimate and Wire-up: A Distribution board with one light point and one power outlet (16A) as sub circuits.
6	<ul style="list-style-type: none"> <li>i) Demonstration of inverter wiring</li> <li>ii) Demonstration of Earthing Schemes.</li> <li>iii) Demonstration of Earth resistance measurement using equipment.</li> </ul>

### **ELECTRONICS WORKSHOP -12 Hrs**

1	<p>Familiarization and identification of active and passive electronic components (Resistor, Capacitor, Inductor, diode, transistor, sensing elements, transformer)</p> <ul style="list-style-type: none"> <li>• Calculation of values, Usage of Data Sheets to find various specifications of Components.</li> </ul>
2	<p>Familiarization of Electronic Equipments (Fixed and Variable Power Supply, Function Generator, CRO, Ammeter, Voltmeter etc.)</p> <ul style="list-style-type: none"> <li>• Generation of Periodic waveforms using function generator and measuring various parameters. (Peak Value, Peak to Peak Value, RMS Value, Frequency etc.)</li> <li>• Testing of Diode and Transistors</li> <li>• Measurement of Current and Voltage in Series and Parallel resistor</li> </ul>
3	<p>Implementation of Circuits in bread board</p> <ul style="list-style-type: none"> <li>• Connecting LED from supply (Application of Resistor).</li> <li>• LED Connection using capacitor (Charge Storage application of Capacitor).</li> <li>• Application of Sensing Element (LDR).</li> <li>• Full wave Bridge Rectifier Circuit</li> </ul>
4	<p>Soldering Practice</p> <ul style="list-style-type: none"> <li>• Full Wave Bridge Rectifier</li> </ul>
5	<p>Introduction to Electronic Simulation tools- LT SPICE</p> <ul style="list-style-type: none"> <li>• Voltage and current through Series and Parallel passive components for AC and DC inputs.</li> <li>• Simulation of rectifier circuits.</li> </ul>

**CO Assessment Questions**

1	Identify the best suitable manufacturing processes for a given product/design
2	A team work to fabricate the component as per the given design using available manufacturing methods and submit the report
3	Identify the components in the electric system shown in the drawing and complete the wiring as per the drawing to get the required result
4	Identify the electronic components in the given figure and assemble the component on a circuit board to enable the required function

24MCT110/ 24MCT210	SPORTS AND WELLNESS						L	T	P	J	S	C	Year of Introduction
							2	0	0	0	2	1*	2024
<p><b>Preamble:</b> This course enables the learners to understand how to attain physical fitness, mental well-being, and holistic growth through the combined benefits of sports and yoga. The topics covered in this course are Physical fitness, wellness and exercise programmes, First aid, Fundamentals of Anatomy &amp; physiology in physical education, Postures &amp; nutrition, Sports &amp; games and Yoga &amp; Lifestyle. This course helps the students to develop appreciation of physical activity as a lifetime pursuit and a means to better health.</p>													
<p><b>Prerequisite:</b> NIL</p>													
<p><b>Course Outcomes:</b> After the completion of the course the student will be able to</p>													
<b>CO 1</b>	Demonstrate the need of physical activities and Yoga for the strength, flexibility, and relaxation of mind and body. [Apply level]												
<b>CO 2</b>	Use scientific principles of exercise and training in daily routine. [Apply level]												
<b>CO 3</b>	Apply first aid promptly and appropriately whenever and wherever the need arises. [Apply level]												
<b>CO 4</b>	Identify the importance of the components of health-related fitness, such as cardio respiratory endurance, flexibility, and body composition. [Understand level]												
<b>CO 5</b>	Use the opportunities to participate in sports and games activities with a scientific approach. [Apply level]												
<b>CO - PO MAPPING</b>													
CO	P01	P02	P03	P04	P05	P06	P07	P08	P09	P010	P011	P012	
<b>CO 1</b>								✓	✓	✓		✓	
<b>CO 2</b>								✓	✓	✓		✓	
<b>CO 3</b>						✓		✓	✓	✓		✓	
<b>CO 4</b>								✓	✓	✓		✓	
<b>CO 5</b>								✓	✓	✓		✓	
<b>Assessment Pattern</b>													
Bloom's Category	Continuous Assessment Tools			End Semester Examination									
	Test1	Test 2	Other tools										
Remember	✓	✓	✓	✓									
Understand	✓	✓	✓	✓									

Apply	✓	✓	✓	✓
Analyse			✓	
Evaluate			✓	
Create			✓	

Mark Distribution of CIA					
Course Structure [L-T-P-J]	Attendance	Theory [L- T]			Total Marks
		Assignment	Test-1	Test-2	
2-0-0-0	5	35	30	30	<b>100</b>
Total Mark distribution					
Total Marks	CIA (Marks)	ESE (Marks)		ESE Duration	
100	100	-		-	

<b>SYLLABUS</b>
<b>MODULE I: Physical fitness, wellness and exercise programmes.</b>
<ul style="list-style-type: none"> <li>• Meaning and importance of physical fitness and wellness.</li> <li>• Components of physical fitness and health related fitness.</li> <li>• How to start an exercise programme.</li> <li>• Exercise for improving speed, strength, endurance, and flexibility and co ordiative abilities.</li> <li>• Exercises to prevent back pain, tennis elbow, shoulder injury and knee pain, Neck pain.</li> <li>• Fitness test battery for speed, strength, endurance, flexibility.</li> <li>• Importance of weight training.</li> <li>• Warming up and cooling down.</li> <li>• How to deal with every day stress.</li> </ul>
<b>MODULE II : First aid</b>
<ul style="list-style-type: none"> <li>• First aid and principles of first aid</li> <li>• First aid measure for the following – Bleeding through Nose, Snakebite, Dog Bite, Electric Shock, Burns and Drowning</li> <li>• Common injuries and their management - Wounds, Cuts, Sprain, Fracture and Dislocation.</li> <li>• Cardio Pulmonary Resuscitation. (CPR)</li> <li>• How to prevent muscle cramps and its management.</li> <li>• How to carry an injured person.</li> </ul>

### **MODULE III : Fundamentals of Anatomy and physiology in physical education, Postures and nutrition**

- Define Anatomy, physiology and its importance.
- Effects of exercise on the functioning of various body system (Circulatory system, muscular system and respiratory system)
- Posture and its importance.
- Common Postural Deformities-Knock Knee, Flat Foot, Round Shoulders, Lordosis, Kyphosis, Bow Legs and Scoliosis.
- Corrective Measures for Postural Deformities.
- Balanced diet, malnutrition and Deficiency diseases.
- Hydration.

### **MODULE IV : Sports and games**

- Following subtopics related to anyone game/sport of choice of student out of Football, Shuttle badminton, Volleyball, Basketball, Tennis and Cricket
- History of the game / sports.
- Latest general rule of the game / sports.
- Specification of play fields and related sports equipments

### **MODULE V : Yoga & Lifestyle**

- Meaning & importance of Yoga.
- Elements of Yoga
- Introduction-Asanas, Pranayama, Meditation & Yogic Kriyas.
- Yoga for concentration & related Asanas (Sukhasana; Tadasana; Padmasana & Shashankasana)
- Relaxation Techniques for improving concentration-Yog-nidra.
- Asanas as preventive measure.
- Hypertension: Tadasana, Vajrasana, Pavan Muktasana, Ardha Chakrasana, Bhujangasana, Sharasana.
- Obesity: Procedure, Benefits & contraindications for Vajrasana, Hastasana, Trikonasana, Ardh Matsyendrasana.
- Back pain: Tadasana, Ardh Matsyendrasana, Vakrasana, Shalabhasana, Bhujangasana.
- Diabetes: Procedure, Benefits & Contraindications for Bhujangasana, Paschimottasana, Pavan Muktasana, Ardh Matsyendrasana.
- Asthema: Procedure, Benefits & Contraindications for Sukhasana, Chakrasana, Gomukhasana, Parvatasana, Bhujangasana, Paschimottasana, Matsyasana.

#### **Text books**

1. Modern Trends and Physical Education by Prof. Ajmer Singh.
2. Light on Yoga by B.K.S. Iyengar.
3. Health and Physical Education- NCERT (11th and 12th Classes)

#### **Reference books**

1. Physiological aspects of sports training and performance by Jay Hoffman.
2. Periodization theory and methodology of training by Tudor O Bompa and G

Grisgery Haff.

3. Essential of strength training and conditioning by Thomas Baechle E R, Roger W Earle.
4. A practice guide to emergency first aid, safety injuries, illnesses by Montreal.
- 5.

### **COURSE CONTENTS AND LECTURE SCHEDULE**

No.		No. of Hours [26]
<b>MODULE 1: Physical fitness, wellness and exercise programmes.</b>		
1.1	<ul style="list-style-type: none"> <li>• Meaning and importance of physical fitness and wellness.</li> <li>• Components of physical fitness and health related fitness.</li> </ul>	1 Hour
1.2	<ul style="list-style-type: none"> <li>• How to start an exercise programme.</li> <li>• Exercise for improving speed, strength, endurance, and flexibility and co ordinative abilities.</li> </ul>	1 Hour
1.3	<ul style="list-style-type: none"> <li>• Exercises to prevent back pain, tennis elbow, shoulder injury and knee pain, Neck pain.</li> </ul>	1 Hour
1.4	<ul style="list-style-type: none"> <li>• Fitness test battery for speed, strength, endurance, flexibility.</li> </ul>	1 Hour
1.5	<ul style="list-style-type: none"> <li>• Importance of weight training.</li> <li>• Warming up and cooling down.</li> </ul>	1 Hour
1.6	<ul style="list-style-type: none"> <li>• How to deal with every day stress.</li> </ul>	1 Hour
<b>MODULE II: First aid</b>		
2.1	<ul style="list-style-type: none"> <li>• First aid and principles of first aid</li> <li>• First aid measure for the following – Bleeding through Nose, Snakebite, Dog Bite, Electric Shock, Burns and Drowning.</li> </ul>	1 Hour
2.4	<ul style="list-style-type: none"> <li>• Common injuries and their management - Wounds, Cuts, Sprain, Fracture and Dislocation.</li> </ul>	1 Hour
2.5	<ul style="list-style-type: none"> <li>• Cardio pulmonary resuscitation. (CPR)</li> </ul>	1 Hour
2.6	<ul style="list-style-type: none"> <li>• How to prevent muscle cramps and its management.</li> <li>• How to carry an injured person</li> </ul>	1 Hour
<b>MODULE III: Fundamentals of Anatomy and physiology in physical education, Postures and nutrition</b>		
3.1	<ul style="list-style-type: none"> <li>• Define Anatomy, physiology and its importance.</li> <li>• Effects of exercise on the functioning of various body system (Circulatory system, muscular system and respiratory system)</li> </ul>	1 Hour
3.2	<ul style="list-style-type: none"> <li>• Posture and its importance.</li> <li>• Common Postural Deformities-Knock Knee; Flat Foot; Round Shoulders; Lordosis, Kyphosis, Bow Legs and Scoliosis.</li> <li>• Corrective Measures for Postural Deformities.</li> </ul>	1 Hour
3.3	<ul style="list-style-type: none"> <li>• Balanced diet, mal nutrition and Deficiency disease.</li> </ul>	1 Hour
3.4	<ul style="list-style-type: none"> <li>• Hydration.</li> </ul>	1 Hour

<b>MODULE IV: Sports and games.</b>		
Following subtopics related to anyone game/sport of choice of student out of		
4.1	<ul style="list-style-type: none"> <li>• Football</li> </ul>	1 Hour
4.2	<ul style="list-style-type: none"> <li>• Shuttle badminton</li> </ul>	1 Hour
4.3	<ul style="list-style-type: none"> <li>• Volleyball</li> </ul>	1 Hour
4.4	<ul style="list-style-type: none"> <li>• Basketball</li> </ul>	1 Hour
4.5	<ul style="list-style-type: none"> <li>• Cricket</li> </ul>	1 Hour
4.6	<ul style="list-style-type: none"> <li>• Tennis</li> <li>• History of the game / sports.</li> <li>• Latest general rule of the game / sports.</li> <li>• Specification of play fields and related sports equipments.</li> </ul>	1 Hour
<b>Module 5-Yoga &amp; Lifestyle</b>		
5.1	<ul style="list-style-type: none"> <li>• Meaning &amp; importance of Yoga.</li> <li>• Elements of Yoga</li> <li>• Introduction-Asanas, Pranayama, Meditation &amp; Yogic Kriyas.</li> <li>• Yoga for concentration &amp; related Asanas (Sukhasana; Tadasana; Padmasana &amp; Shashankasana)</li> <li>• Relaxation Techniques for improving concentration-Yog-nidra.</li> <li>• Asanas as preventive measures</li> </ul>	1 Hour
5.2	<ul style="list-style-type: none"> <li>• Hypertension: Tadasana, Vajrasana, Pavan Muktasana, Ardha Chakrasana, Bhujangasana, Sharasana.</li> <li>• Obesity: Procedure, Benefits &amp; contraindications for Vajrasana, Hastasana, Trikonasana, Ardh Matsyendrasana.</li> <li>• Back pain: Tadasana, Ardh Matsyendrasana, Vakrasana, Shalabhasana, Bhujangasana.</li> </ul>	1 Hour
5.3	<ul style="list-style-type: none"> <li>• Diabetes: Procedure, Benefits &amp; Contraindications for Bhujangasana, Paschimottasana, Pavan Muktasana, Ardh Matsyendrasana.</li> </ul>	1 Hour
5.4	<ul style="list-style-type: none"> <li>• Asthema: Procedure, Benefits &amp; Contraindications for Sukhasana, Chakrasana, Gomukhasana, Parvatasana, Bhujangasana, Paschimottasana, Matsyasana.</li> </ul>	1 Hour

<b>CO Assessment Questions</b>	
1	<ol style="list-style-type: none"> <li>1. Group Activity - Group discussion about the need and benefits of physical activities and Yoga for the strength, flexibility, and relaxation of mind &amp; body.</li> <li>2. Make a demonstrative video about various yoga poses with the members in your team - Break down the yoga poses that you learned into smaller steps or stages. Demonstrate each step slowly and methodically, explaining the alignment, placement of body parts, and any variations or modifications.</li> </ol>



	Emphasize proper breathing techniques throughout the demonstration.
2	<ol style="list-style-type: none"> <li>1. Analyze the exercise activities of at least five famous personalities and give a PPT presentation about how each one of them uses physiological principles related to exercise and training in daily routine.</li> <li>2. Conduct a survey on how the following categories of people follow physiological principles related to exercise and training in daily routine. <ol style="list-style-type: none"> <li>1. Sports person</li> <li>2. Working woman</li> <li>3. Students</li> <li>4. Ladies in the age group of 25-35, 35-45,45- 55,55-65, above 65</li> <li>5. Gents in the age group of 25-35, 35-45,45- 55,55-65, above 65</li> </ol> </li> </ol> <p>Prepare a survey form and conduct the survey. Based on the survey give a presentation about your findings and demonstrate whether it matches with the concepts you learned.</p>
3	<p>With a role play, illustrate various first aid activities that can be followed at various situation in life. In each illustration, try to give emphasis on dos and don'ts to be followed in each situation.</p> <p>Observe at least 10 students in your class and identify Common Postural Deformities each one of them have. Also identify good postures they follow. Have a discussion with each one of them to identify whether they have already recognized it or not. Make a report about it.</p>
4	Create a video presentation about the exercises to prevent back and shoulder pain.
5	<p>Create a PPT presentation on the rules of any one of the sports items given below. Try to identify the rules violated by some players in some popular competition and include those cases in the PPT.</p> <ul style="list-style-type: none"> <li>• Football</li> <li>• Shuttle badminton</li> <li>• Volleyball</li> <li>• Basketball</li> <li>• Cricket</li> <li>• Tennis</li> </ul>

<b>24HUT211</b>	<b>Universal Human Values-II</b>	<b>L</b>	<b>T</b>	<b>P</b>	<b>J</b>	<b>S</b>	<b>C</b>	<b>Year of Introduction</b> <b>2024</b>
		<b>2</b>	<b>1</b>	<b>0</b>	<b>0</b>	<b>2</b>	<b>3</b>	

**Preamble:** This course helps the students to appreciate the essential complementarity between 'VALUES' and 'SKILLS' to ensure sustained happiness and prosperity which are the core aspirations of all human beings. The topics covered in this course are the concepts of self exploration, values and skills, happiness and prosperity, harmony in family and society, harmony in the nature and society, and ethical values needed for the life and profession of an individual. This course enables the learners to develop a holistic perspective towards life and profession & towards happiness and prosperity based on a correct understanding of the human reality and the rest of existence.

**Prerequisite: Universal Human Values I (Student Induction Program)**

**Course Outcomes:** After the completion of the course the student will be able to

<b>CO1</b>	Evaluate the significance of value inputs in formal education and start applying them in their life and profession. [Apply level]
<b>CO2</b>	Distinguish between values and skills, happiness and accumulation of physical facilities, the Self and the Body, Intention and Competence of an individual. [Analyse level]
<b>CO3</b>	Demonstrate the value of harmonious relationship based on trust and respect in their life and profession. [Analyse level]
<b>CO4</b>	Examine the role of a human being in ensuring harmony in society and nature. [Analyse level]
<b>CO5</b>	Use the understanding of ethical conduct to formulate the strategy for ethical life and profession. [Apply level]

**CO - PO MAPPING**

<b>CO</b>	<b>PO1</b>	<b>PO2</b>	<b>PO3</b>	<b>PO4</b>	<b>PO5</b>	<b>PO6</b>	<b>PO7</b>	<b>PO8</b>	<b>PO9</b>	<b>PO10</b>	<b>PO11</b>	<b>PO12</b>
<b>CO1</b>						✓	✓	✓	✓	✓		✓
<b>CO2</b>						✓	✓	✓	✓	✓		✓
<b>CO3</b>						✓	✓	✓	✓	✓		✓
<b>CO4</b>						✓	✓	✓	✓	✓		✓
<b>CO5</b>						✓	✓	✓	✓	✓		✓

**Assessment Pattern**

<b>Bloom's Category</b>	<b>Continuous Assessment Tools</b>			<b>End Semester Examination</b>
	<b>Test 1</b>	<b>Test 2</b>	<b>Other tools</b>	
Remember	✓	✓	✓	✓
Understand	✓	✓	✓	✓
Apply	✓	✓	✓	✓
Analyse				
Evaluate				
Create				

**Mark Distribution of CIA**

<b>Course Structure</b> <b>[L-T-P-J]</b>	<b>Attendance</b>	<b>Theory [L- T]</b>			<b>Total Marks</b>
		<b>Assignment</b>	<b>Test-1</b>	<b>Test-2</b>	
<b>2-1-0-0</b>	5	15	10	10	<b>40</b>

**Total Mark distribution**

<b>Total Marks</b>	<b>CIA (Marks)</b>	<b>ESE (Marks)</b>	<b>ESE Duration</b>
--------------------	--------------------	--------------------	---------------------

100	40	60	3 hours
<b>End Semester Examination [ESE]: Pattern</b>			
<b>PATTERN</b>	<b>PART A</b>	<b>PART B</b>	<b>ESE Marks</b>
PATTERN 1	10 Questions, each question carries 2 marks  Marks: (2x10 =20 marks)	2 questions will be given from each module, out of which 1 question should be answered. Each question can have a maximum of 2 sub divisions. Each question carries 8 marks. Marks: (5x8 = 40 marks) Time: 3 hours	60
	Total Marks: 20	Total Marks: [5x8 = 40 marks]	
<b>SYLLABUS</b>			
<b>MODULE I : Introduction to Value Education</b>			
Right Understanding, Relationship and Physical Facility (Holistic Development and the Role of Education), Understanding Value Education, Self-exploration as the Process for Value Education, Continuous Happiness and Prosperity – the Basic Human Aspirations, Happiness and Prosperity – Current Scenario, Method to Fulfill the Basic Human Aspirations.			
<b>MODULE II : Harmony in the Human Being</b>			
Understanding Human being as the Co-existence of the Self and the Body, distinguishing between the Needs of the Self and the Body, The Body as an Instrument of the Self, Understanding Harmony in the Self, Harmony of the Self with the Body, Programme to ensure self-regulation and Health.			
<b>MODULE III : Harmony in the Family and Society</b>			
Harmony in the Family – the Basic Unit of Human Interaction, 'Trust' – the Foundational Value in Relationship, 'Respect' – as the Right Evaluation, Other Feelings, Justice in Human-to-Human Relationship, Understanding Harmony in the Society, Vision for the Universal Human Order.			
<b>MODULE IV: Harmony in the Nature/Existence</b>			
Understanding Harmony in the Nature, Interconnectedness, self-regulation and Mutual Fulfillment among the Four Orders of Nature, Realizing Existence as Co-existence at All Levels, Holistic Perception of Harmony in Existence.			
<b>MODULE V: Implications of the Holistic Understanding – a Look at Professional Ethics</b>			
Natural Acceptance of Human Values, Definitiveness of (Ethical) Human Conduct, A Basis for Humanistic Education, Humanistic Constitution and Universal Human Order, Competence in Professional Ethics, Holistic Technologies, Production Systems and Management Models- Typical, Strategies for Transition towards Value-based Life and Profession.			
<b>Text books</b>			
1. A Foundation Course in Human Values and Professional Ethics, R R Gaur, R Asthana, G P Bagaria, 2nd Revised Edition, Excel Books, New Delhi, 2019. ISBN 978-93-87034-47-1			
2. Teachers' Manual for A Foundation Course in Human Values and Professional Ethics, RR Gaur, R Asthana, G P Bagaria, 2nd Revised Edition, Excel Books, New Delhi, 2019.			

**Reference books**

1. JeevanVidya: EkParichaya, A Nagaraj, JeevanVidyaPrakashan, Amarkantak, 1999.
2. Human Values, A.N. Tripathi, New Age Intl. Publishers, New Delhi, 2004.
3. The Story of Stuff (Book). Annie Leonard, Publisher: Free Press (February 22, 2011), ISBN13: 9781451610291
4. The Story of My Experiments with Truth - by Mohandas Karamchand Gandhi

**COURSE CONTENTS AND LECTURE SCHEDULE**

No.		No. of Hours [36 ]
<b>MODULE 1</b>		
1.1	Understanding Value Education	1
1.2	Tutorial 1- Sharing about Oneself	1
1.3	Self-exploration as the Process for Value Education	1
1.4	Continuous Happiness and Prosperity – the Basic Human Aspirations	1
1.5	Tutorial 2 - Exploring Human Consciousness	1
1.6	Happiness and Prosperity – Current Scenario	1
1.7	Method to Fulfill the Basic Human Aspirations	1
1.8	Tutorial 3 - Exploring Natural Acceptance	1
<b>MODULE II</b>		
2.1	Understanding Human being as the Co-existence of the Self and the Body	1
2.2	Distinguishing between the Needs of the Self and the Body	1
2.3	Tutorial 1 - Exploring the difference of Needs of Self and Body	1
2.4	The Body as an Instrument of the Self and Understanding Harmony in the Self	1
2.5	Tutorial 2 - Exploring Sources of Imagination in the Self	1
2.6	Harmony of the Self with the Body	1
2.7	Programme to ensure self-regulation and Health	1
2.8	Tutorial 3 - Exploring Harmony of Self with the Body	1
<b>MODULE III</b>		
3.1	Harmony in the Family – the Basic Unit of Human Interaction	1
3.2	'Trust' – the Foundational Value in Relationship	1
3.3	Tutorial 1 - Exploring the Feeling of Trust	1
3.4	'Respect' – as the Right Evaluation	1
3.5	Tutorial 2 - Exploring the Feeling of Respect	1
3.6	Other Feelings, Justice in Human-to-Human Relationship	1
3.7	Understanding Harmony in the Society and Vision for the Universal Human Order	1
3.8	Tutorial 3 - Exploring Systems to fulfill Human Goal	1
<b>MODULE IV</b>		
4.1	Understanding Harmony in the Nature, Interconnectedness, self-regulation and Mutual Fulfillment among the Four Orders of Nature	1
4.2	Tutorial 1 - Exploring the Four Orders of Nature	1

4.3	Realizing Existence as Co-existence at All Levels	1
4.4	The Holistic Perception of Harmony in Existence	1
4.5	Tutorial 2 - Exploring Co-existence in Existence	1
<b>MODULE V</b>		
5.1	Natural Acceptance of Human Values, Definitiveness of (Ethical) Human Conduct	1
5.2	Exploring Ethical Human Conduct	1
5.3	A Basis for Humanistic Education, Humanistic Constitution and Universal Human Order, Professional Ethics	1
5.4	Exploring Humanistic Models in Education	1
5.5	Holistic Technologies, Production Systems and Management Models-Typical Case Studies	1
5.6	Strategies for Transition towards Value-based Life and Profession	1
5.7	Exploring Steps of Transition towards Universal Human Order	1

### CO Assessment Questions

1	<p>1. What does a fulfilling life mean for you? List out the top five points that occur to you when you think of a fulfilling life. While making the list, please consider your entire life, not just the present stage of your life (youth, middle age, old age, etc.).</p> <p>2. Choose any five things that you consider as human values. Now write all the basic guidelines, and check if you they satisfy the basic guidelines. (Hint: Someone may say Trust is a human value. Now check if it satisfies the basic guidelines.)</p> <p>3. List your activities throughout a typical day in your life. Categorize these activities as activity for developing right understanding, activity for fulfillment in relationship and activity for physical facility (see table, below).</p>			
	<b>Activity</b>	<b>This activity has time and effort for</b>		
		Right understanding	Fulfillment in relationship	Physical facility
	Exercise, playing games (2 hrs/day)	?	?	2 hrs (for health of body)
	Talking with friends	?	3 hrs (for relationship)	?
	Studying	1 hr (studying for values)	?	6 hrs (studying for skills)
	Sleeping			
	This is just a sample list. Please make your own list			
	Total Time and Effort		Max 24 hrs	
	Find out what percentage of your time and effort is being spent for each of these three. What do you conclude from this exercise?			
2	Find out if the following are naturally acceptable to you.			

	<b>Statement</b>	<b>My present thinking (beliefs) about the statement</b>	<b>Naturally Acceptable?</b>
	I want to be happy		
	I want to make others happy		
	I want to be healthy		
	I want to live in relationship		
	I want to have more than others		
	I want to have more than what I really need		
	Feeling of respect in relationship	Only if you have money, people respect you	Feeling of respect is naturally acceptable in relationship
	<p>Can you observe that when you really try, you can refer to your natural acceptance? Note any five things that appear naturally acceptable to you. Now, verify for yourself that your 'natural acceptance' does not change with time or place. It does not depend on your beliefs and past conditionings and that it is always there. If not, would you still call it your natural acceptance? And if not, what can it be termed as in place of natural acceptance? e.g., eating sweets. It may appear naturally acceptable. Now explore, whether it changes with time, place and individual or not. You will see that sometimes you like eating sweets, while sometimes; you do not feel like eating sweets. Same thing happens with place. And not everyone wants to eat sweets. Thus, it does not fulfill the criterion. It is not your 'natural acceptance'. Then what is your natural acceptance? Find it out (here, while eating sweets is your liking, nurturing your Body is the natural acceptance).</p>		
3	<ol style="list-style-type: none"> <li>1. "The pleasures that we derive from sensations are short lived and the efforts to extend them lead to misery" -Examine and illustrate this statement with an example.</li> <li>2. Explain the activities of imaging, analyzing and selecting/tasting with a diagram. With the help of an example, show how are they related.</li> <li>3. "If I trust everyone, people would take undue advantage of me." Do you agree? Explain.</li> <li>4. "When we are assured of the intention of the other and find that the competence is lacking, we become a help to the other. When we doubt the intention of the other, we get into opposition." Explain.</li> </ol>		
4	<ol style="list-style-type: none"> <li>1. What in your opinion, is an effective way of ensuring prosperity in the family? What programs can you undertake in this respect?</li> <li>2. Indicate a few feasible steps to promote harmony in the society and co-existence with nature.</li> <li>3. "Other than human order, the three orders are mutually fulfilling to each other." Explain with examples. Why does human order fail to be mutually fulfilling to itself and to the other orders?</li> </ol>		

5

1. How does right understanding provide the basis for ethical human conduct? Give two examples.
2. What are the values in interaction of human beings with the material things? Give one example of each.
3. Visualize a framework for humanistic education for children. Suggest a few ways to modify present day school education.
4. Choose any one dimension (education, health, production, justice, exchange) of human endeavor in a society. Suggest what role can you play in the chosen dimension through the orientation you are going to have through your professional education.